



2506 South Elm Street
 Greenville, IL 62246
 www.enertechmfg.com
 info@enertechmfg.com

Installation, Operation & Maintenance: Split Series Units

Rev.: 14 June 2011D

P/N:  23-23-0031-001

Table of Contents:

Section 1: Model Nomenclature
 Model Nomenclature2 - 5

Section 2: Introduction
 Introduction, Pre-Installation, Components6 - 7

Section 3: Installation Considerations
 Installation Considerations8

Section 4: Compressor Section Physical Data
 Unit Dimensional Data9

Section 5: Air Handler Section / "A" Coil Physical Data
 Unit Physical Data 10 - 11

Section 6: Electrical Data
 Unit Electrical Data 12 - 13

Section 7: Installation
 Unit Placement 14
 A: Ductwork Installation..... 14 - 16
 B: Filter Drier Installation 17
 C: Line Set Installation..... 18 - 25

Section 8: Unit Piping Installation
 Interior Piping, Water Quality26 - 30

Section 9: Antifreeze
 Overview.....31
 Antifreeze Charging32 - 33

Section 10: Desuperheater Installation
 Installation34 - 37

Section 11: Controls
 A: Controls & Wiring Diagrams.....38 - 43

Section 12: Accessories
 APSMA Pump Sharing Module44

Section 13: Troubleshooting
 Troubleshooting45 - 53

Section 14: Forms
 Troubleshooting, Unit Start-Up..... 55 & 57

Guide Revision Table:

Date	By	Page	Note
14 Jun 2011	DS	11	Updated ACD024 & 036 to Revision B
22 Apr 2011	DS	48	Added New CFM Chart
22 Apr 2011	DS	2-5	Updated Decoders
05 Nov 2010	DS	7	Added Note Regarding A-Coil Cleaning
05 Nov 2010	DS	All	Updated Decoders
05 Nov 2010	DS	All	Updated Wiring Diagrams
03 Sept 2010	DS	All	Added Rev B TETCO
22 July 2010	DS	43 - 44	Removed Legacy Controls Information
22 July 2010	DS	12 - 13	Discontinued 575V & 460V Models
02 Apr, 2010	AV	11, 28, 42,45-46	Revised "A" Coil Data, Revised Flow Center Data Updated Wiring Diagram
3 Sept, 2009	DS	12 - 13	Updated electrical data
20 Aug, 2009	DS	2 - 3	Updated decoders
20 Aug, 2009	DS	12 - 13	Added Comm'l voltages
30 July, 2009	DS	11	Updated "A" Coil Dimensional Data
27 July, 2009	DS	All	Added TETCO products, AHRI match table
21 July, 2009	DS	All	Removed all R22 data
17 July, 2009	DS	12-13	Updated electrical data
08 Jun 2009	JH	Various	New air handlers/"A" coils
19 Feb 2009	DS	All	First published

Section 1a: GeoComfort® Series Model Nomenclature

Two-Stage Units - Compressor Section

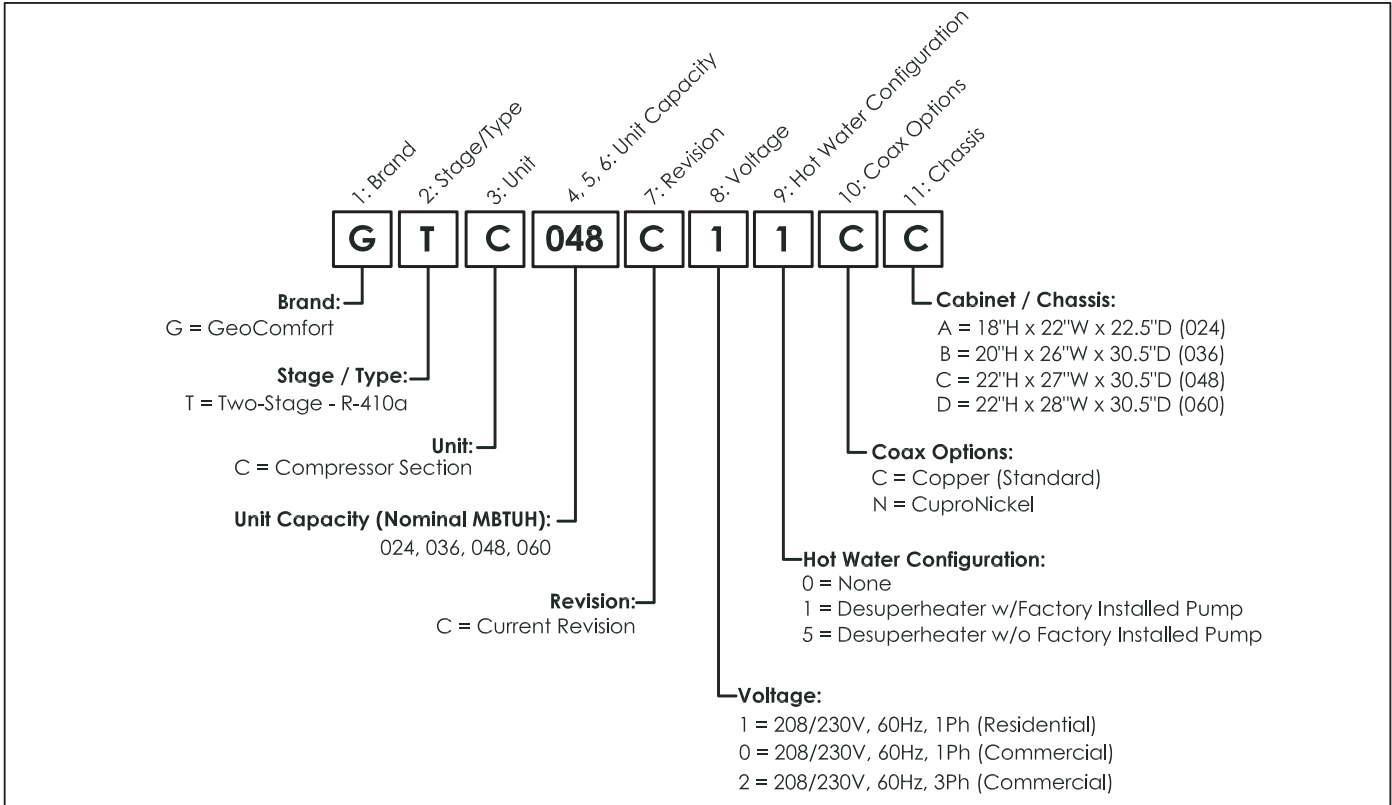

Rev.: 23 March 2011E

Section 1b: Hydron Module® Series Model Nomenclature

Two-Stage Units - Compressor Section

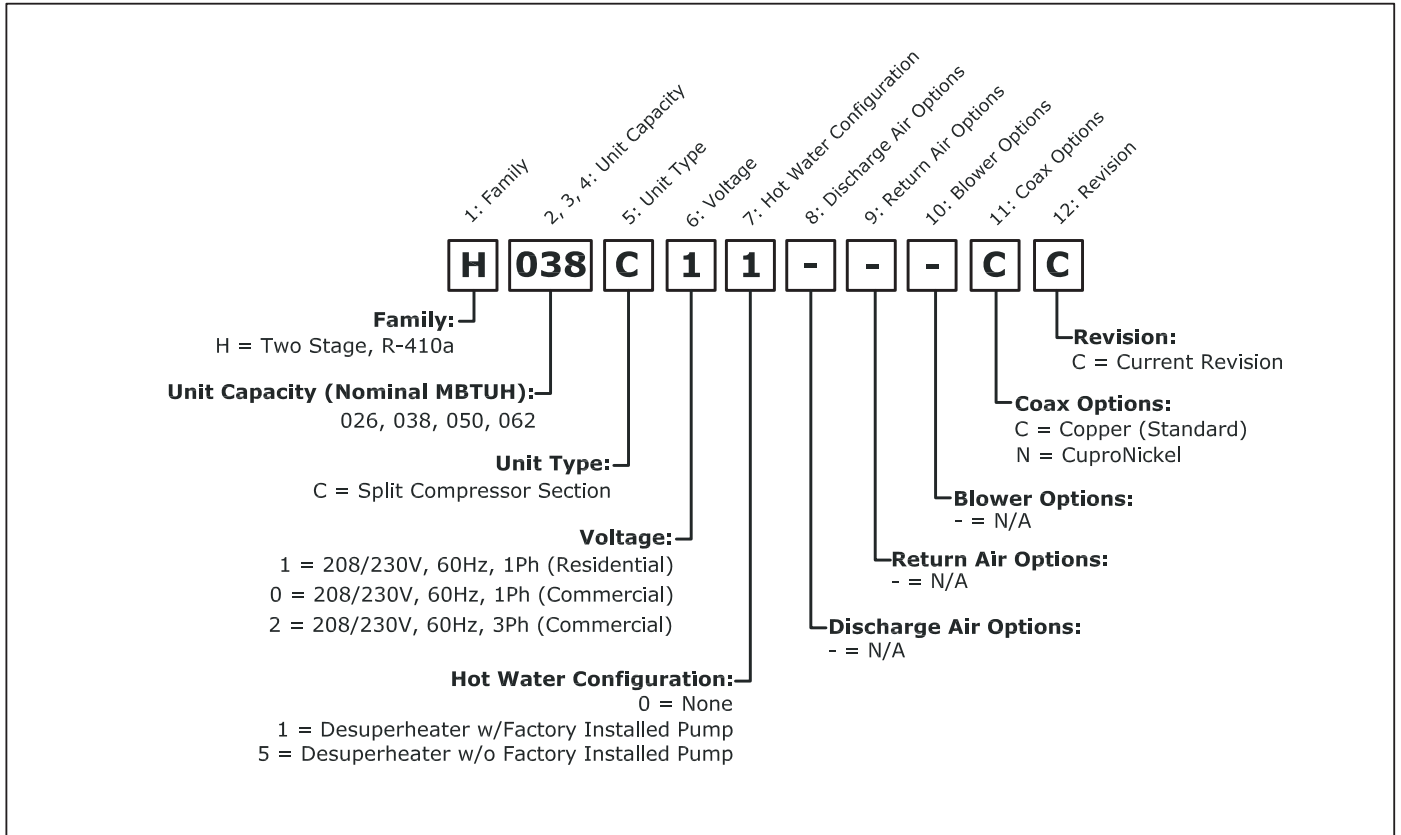

Rev.: 23 March 2011E

Section 1c: TETCO® Series Model Nomenclature

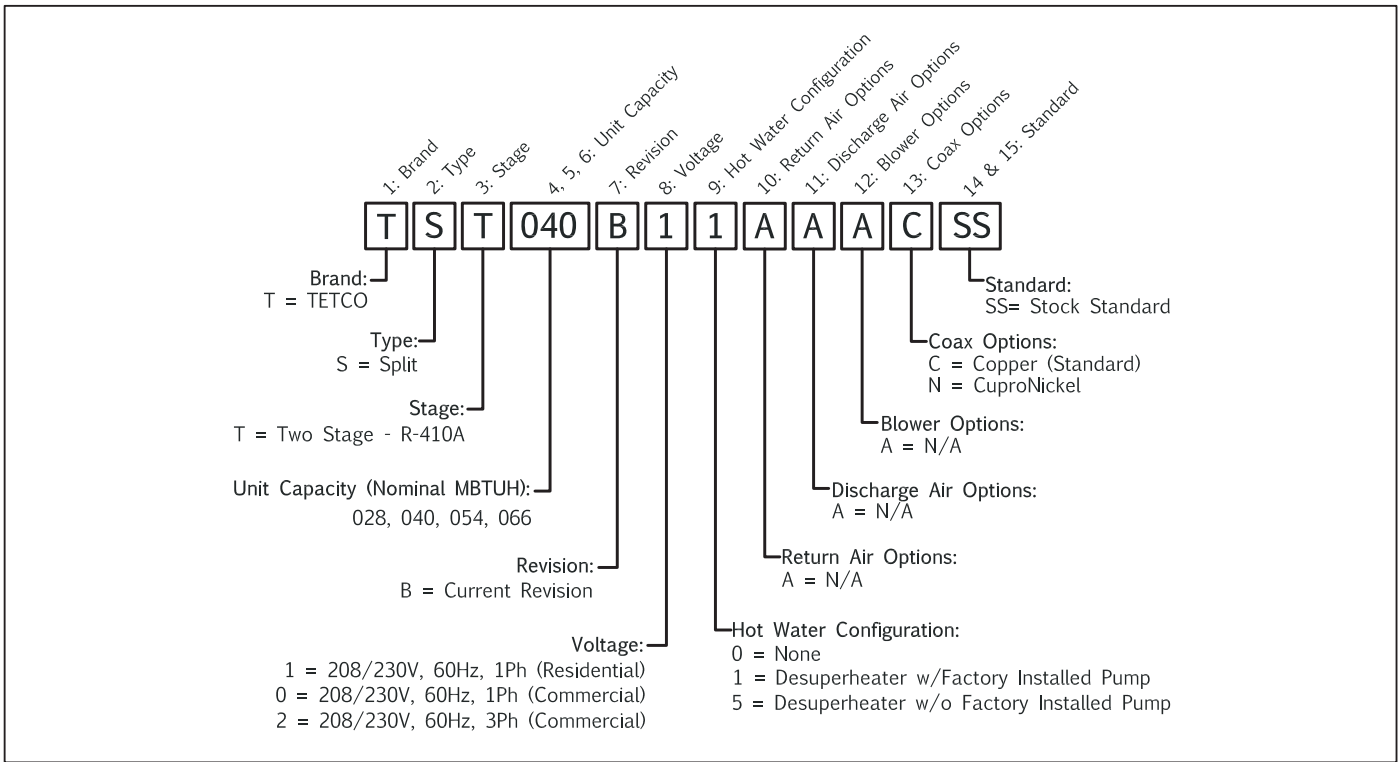

Rev.: 12 Oct 2010E

Section 1d: Air Handler/"A" Coil Model Nomenclature

Air Handlers

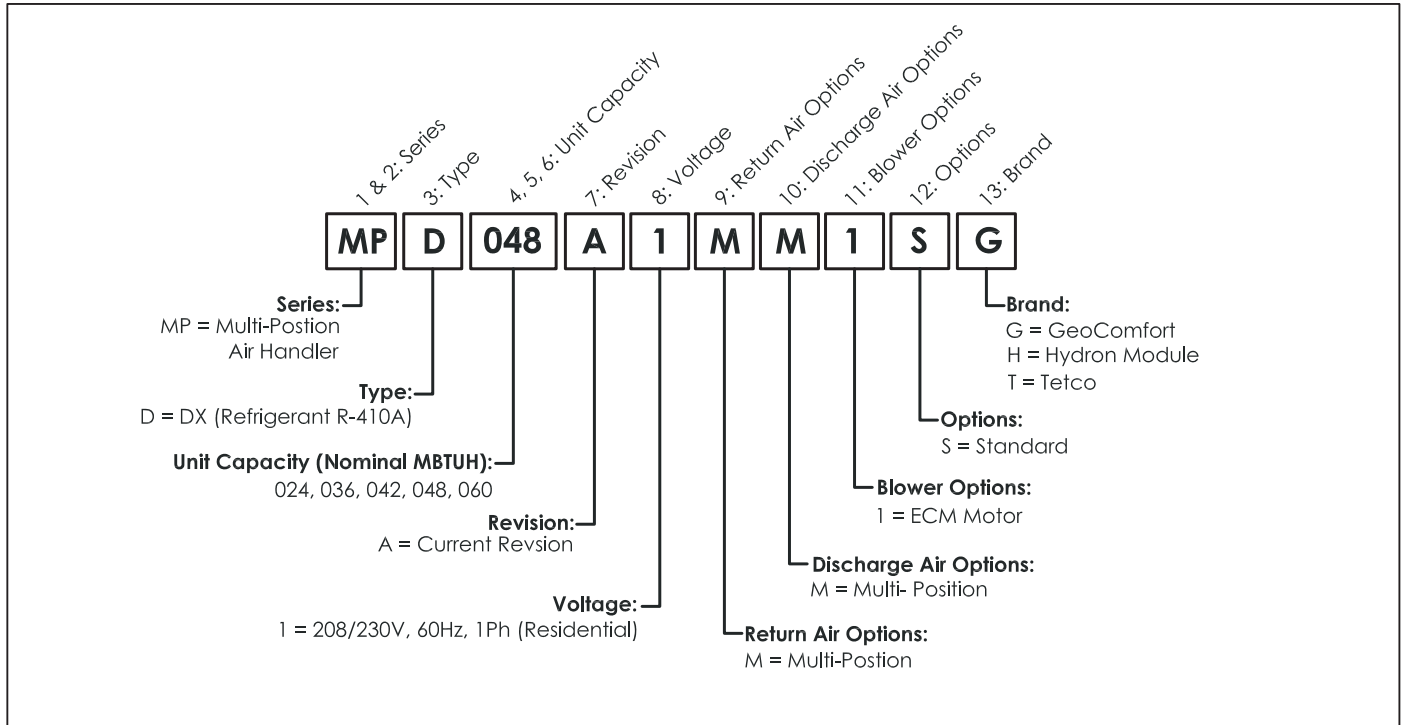

Rev.: 5 Nov 2010E

"A" Coils

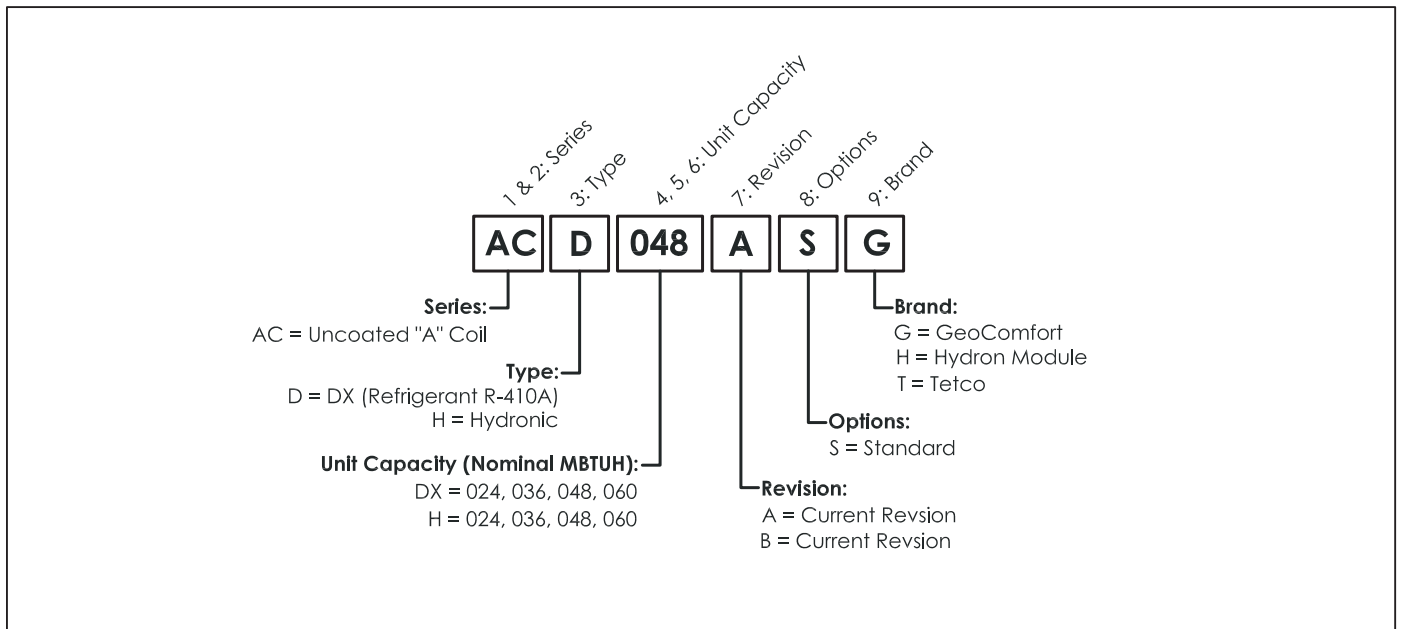

Rev.: 19 April 2011E

Section 2: Introduction

INTRODUCTION

This geothermal heat pump provides heating and cooling as well as optional domestic water heating capability. Engineering and quality control is built into every geothermal unit. Good performance depends on proper application and correct installation.

Notices, Cautions, Warnings, & Dangers

“NOTICE” Notification of installation, operation or maintenance information which is important, but which is NOT hazard-related.

“CAUTION” Indicates a potentially hazardous situation or an unsafe practice which, if not avoided, COULD result in minor or moderate injury or product or property damage.

“WARNING” Indicates potentially hazardous situation which, if not avoided, COULD result in death or serious injury.

“DANGER” Indicates an immediate hazardous situation which, if not avoided, WILL result in death or serious injury.

Inspection

Upon receipt of any geothermal equipment, carefully check the shipment against the packing slip and the freight company bill of lading. Verify that all units and packages have been received. Inspect the packaging of each package and each unit for damages. Insure that the carrier makes proper notation of all damages or shortage on all bill of lading papers. Concealed damage should be reported to the freight company within 15 days. If not filed within 15 days the freight company can deny all claims.

Note: Notify Enertech Manufacturing, LLC shipping department of all damages within 15 days. It is the responsibility of the purchaser to file all necessary claims with the freight company.

Unit Protection

Protect units from damage and contamination due to plastering (spraying), painting and all other foreign materials that may be used at the job site. Keep all units covered on the job site with either the original packaging or

equivalent protective covering. Cap or recap unit connections and all piping until unit is installed. Precautions must be taken to avoid physical damage and contamination which may prevent proper start-up and may result in costly equipment repair.

⚠ CAUTION ⚠

DO NOT OPERATE THE GEOTHERMAL HEAT PUMP UNIT DURING BUILDING CONSTRUCTION PHASE.

Storage

All geothermal units should be stored inside in the original packaging in a clean, dry location. Units should be stored in an upright position at all times. Units should not be stacked unless specially noted on the packaging.

Pre-Installation

Special care should be taken in locating the geothermal unit. Installation location chosen should include adequate service clearance around the unit. All units should be placed on a vibration-absorbing pad (air pad) slightly larger than the base of the unit. All units should be located in an indoor area where the ambient temperature will remain above 55°F and should be located in a way that piping and ductwork or other permanently installed fixtures do not have to be removed for servicing and filter replacement.

Pre-Installation Steps:

1. Compare the electrical data on the unit nameplate with packing slip and ordering information to verify that the correct unit has been shipped.
2. Remove any packaging used to support blower during shipping.
3. Inspect all electrical connections and wires. Connections must be clean and tight at the terminals, and wires should not touch any sharp edges or copper pipe.
4. Verify that all refrigerant tubing is free of dents and kinks. Refrigerant tubing should not be touching other unit components.

Section 2: Introduction

5. Before unit start-up, read all manuals and become familiar with unit components and operation. Thoroughly check the unit before operating.
6. For A-Coil installations, it is recommended that coil be sprayed with liquid detergent thoroughly and rinsed thoroughly before installation to assure proper drainage of condensate from the coil fins to eliminate water blowoff and to assure maximum coil performance. If not sprayed approximately 50 hours of break in time is required to achieve the same results.

⚠ CAUTION ⚠

ALL GEOTHERMAL EQUIPMENT IS DESIGNED FOR INDOOR INSTALLATION ONLY. DO NOT INSTALL OR STORE UNIT IN A CORROSIVE ENVIRONMENT OR IN A LOCATION WHERE TEMPERATURE AND HUMIDITY ARE SUBJECT TO EXTREMES. EQUIPMENT IS NOT CERTIFIED FOR OUTDOOR APPLICATIONS. SUCH INSTALLATION WILL VOID ALL WARRANTIES.

⚠ WARNING ⚠

FAILURE TO FOLLOW THIS CAUTION MAY RESULT IN PERSONAL INJURY. USE CARE AND WEAR APPROPRIATE PROTECTIVE CLOTHING, SAFETY GLASSES AND PROTECTIVE GLOVES WHEN SERVICING UNIT AND HANDLING PARTS.

⚠ CAUTION ⚠

BEFORE DRILLING OR DRIVING ANY SCREWS INTO CABINET, CHECK TO BE SURE THE SCREW WILL NOT HIT ANY INTERNAL PARTS OR REFRIGERANT LINES.

Components

Master Contactor: Energizes Compressor and optional Hydronic Pump and/or Desuperheater package.

Logic Board: Logic Board operates the compressor and protects unit by locking out when safety switches are engaged. It also provides fault indicator(s).

Terminal Strip: Provides connection to the thermostat or other accessories to the low voltage circuit.

Transformer: Converts incoming (source) voltage to 24V AC.

Low Voltage Breaker: Attached directly to transformer, protects the transformer and low voltage circuit.

Reversing Valve: Controls the cycle of the refrigerant system (heating or cooling). Energized in cooling mode.

High Pressure Switch: Protects the refrigerant system from high refrigerant pressure, by locking unit out if pressure exceeds setting.

Low Pressure Switch: Protects the refrigerant system from low suction pressure, if suction pressure falls below setting.

Flow Switch (Freeze Protection Device): Protects the water heat exchanger from freezing, by shutting down compressor if water flow decreases.

Compressor (Copeland Scroll): Pumps refrigerant through the heat exchangers and pressurizes the refrigerant, which increases the temperature of the refrigerant.

Section 3: Installation Considerations

Consumer Instructions: Dealer should instruct the consumer in proper operation, maintenance, filter replacements, thermostat and indicator lights. Also provide the consumer with the manufacturer's Owner's Manual for the equipment being installed.

Enertech Manufacturing D-I-Y Policy: Enertech Manufacturing's geothermal heat pumps and system installations may include electrical, refrigerant and/or water connections. Federal, state and local codes and regulations apply to various aspects of the installation. Improperly installed equipment can lead to equipment failure and health/safety concerns. For these reasons, only qualified technicians should install a Enertech Manufacturing built geothermal system.

Because of the importance of proper installation, Enertech Manufacturing does not sell equipment direct to homeowners. Internet websites and HVAC outlets may allow for purchases directly by homeowners and do-it-yourselfers, but Enertech Manufacturing offers no warranty on equipment that is purchased via the internet or installed by persons without proper training.

Enertech Manufacturing has set forth this policy to ensure installations of Enertech Manufacturing geothermal systems are done safely and properly. The use of well-trained, qualified technicians helps ensure that your system provides many years of comfort and savings.

Equipment Installation: Special care should be taken in locating the unit. All units should be placed on a vibration absorbing pad (air pad) slightly larger than the base of the unit. All units should be located in an indoor area where the ambient temperature will remain above 55°F and should be located in a way that piping and ductwork or other permanently installed fixtures do not have to be removed for servicing and filter replacement.

Electrical: All wiring, line and low voltage, should comply with the manufacturer's recommendations, The National Electrical Code, and all local codes and ordinances.

Thermostat: Thermostats should be installed approximately 54 inches off the floor on an inside wall in the return air pattern and where they are not in direct sunlight at anytime.

Loop Pumping Modules: Must be wired to the heat pump's electric control box. A special entrance knockout is provided below the thermostat entrance knockout. A pump module connection block, connected to the master contactor, is provided to connect the Pump Module wiring.

Desuperheater Package: Water heating is standard on all residential units (units may be ordered without). It uses excess heat during both heating and cooling cycles, to provide hot water for domestic needs. A desuperheater exchanger (coil) located between the compressor and the reversing valve, extracts superheated vapor to heat domestic water; still satisfying its heating and cooling needs. The water circulation pump comes pre-mounted in all residential units, but must be electrically connected to the master contactor. Leaving it unconnected ensures that the pump is not run without a water supply.

The Desuperheater package can make up to 60% (depending on heat pump usage) of most domestic water needs, but a water heater is still recommended.

Desuperheater Piping: All copper tubes & fittings should be 5/8" O.D (1/2" nom) minimum with a maximum of 50ft separation. Piping should be insulated with 3/8" wall closed cell insulation.

Note: Copper is the only approved material for piping the desuperheater.

Section 4a: Single & Two-Stage R-410a Compressor Section Physical Data

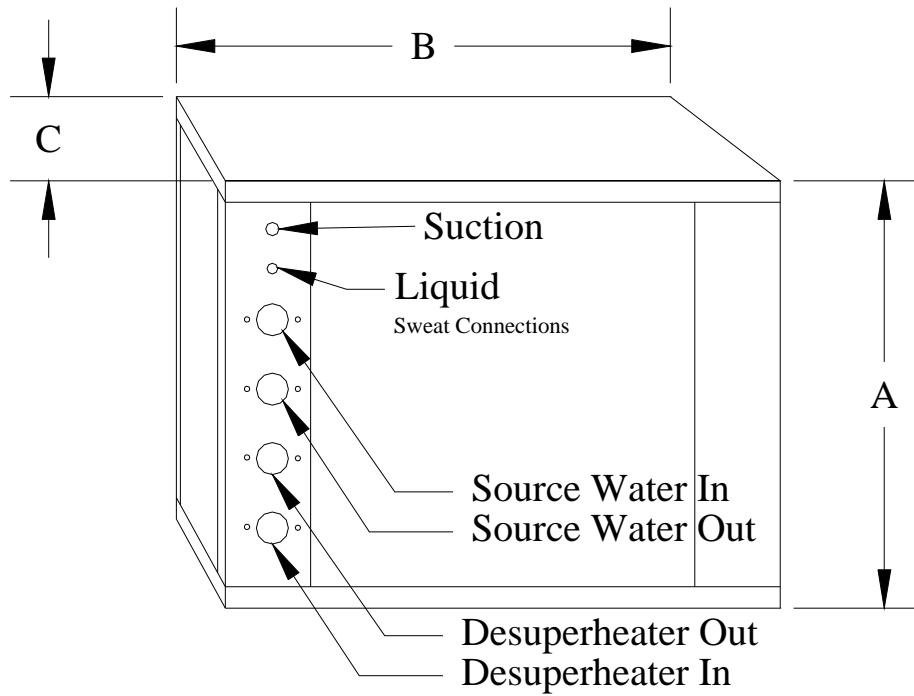

Model	Dimensional Data			Refrigeration Connection		Water Loop*		Desuperheater		Unit Weight (Pounds)	Refrigerant Charge (oz)
	A	B	C	Liquid	Suction	IN	OUT	IN	OUT		
026 - 028	18.8	22.0	25.5	1/2"	5/8"	3/4"	3/4"	3/4"	3/4"	185	57
036 - 040	21.8	26.0	30.5	1/2"	3/4"	3/4"	3/4"	3/4"	3/4"	245	65
048 - 054	22.8	26.0	30.5	1/2"	3/4"	1.0"	1.0"	3/4"	3/4"	265	91
060 - 066	22.8	28.0	30.5	5/8"	7/8"	1.0"	1.0"	3/4"	3/4"	280	99

* Water loop fittings on "B" revision units will be 1" Double O-Ring fittings (GeoComfort brand only)

AHRI Air Handler and "A" Coil Matches

Compressor Section	Air Handler Match	"A" Coil Match
026 - 028	MPD024	ACD024A
036 - 040	MPD036	ACD036A
048 - 054	MPD048	ACD048A
060 - 066	MPD060	ACD060B

Section 5a: MPD Series Air Handler Physical Data

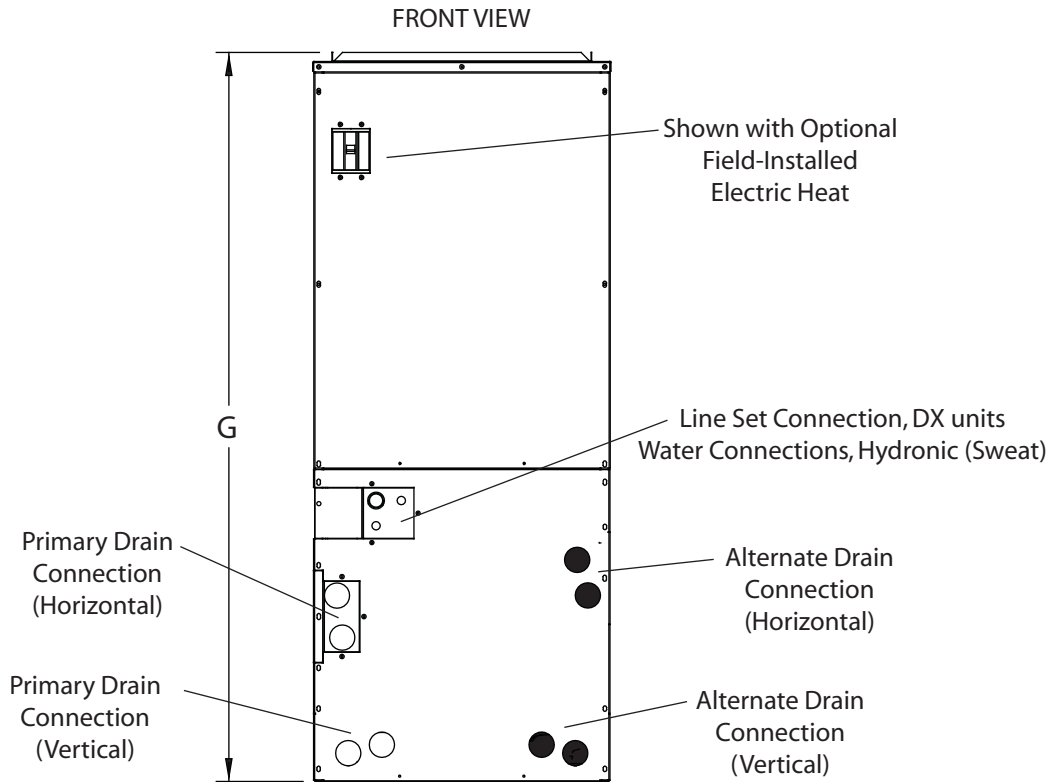

Model	Size (tons)	All Dimensions in Inches						
		A	B	C	D	E	F	G
024	2	17 5/8	21	16 1/3	20 1/4	15 1/2	12 1/2	43
036	3	21 1/8	21	19 3/4	20 1/4	19	12 1/2	48 1/4
042-060	3.5 - 5	25	22	23 3/8	20 1/2	22 1/4	14 1/4	58 3/4

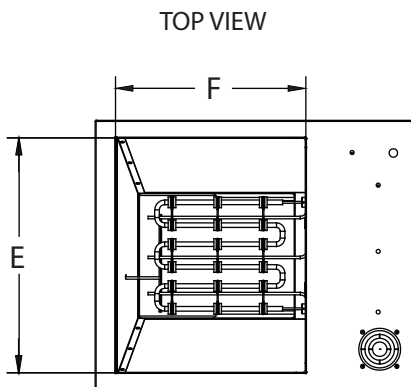

Shown with Optional Field-Installed Electric Heat

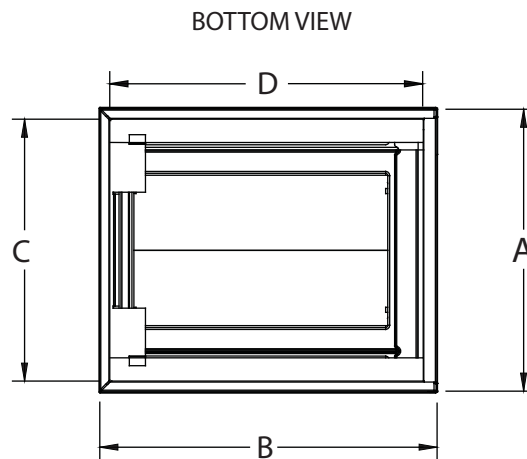

Section 5b: AC Series "A" Coil Physical Data

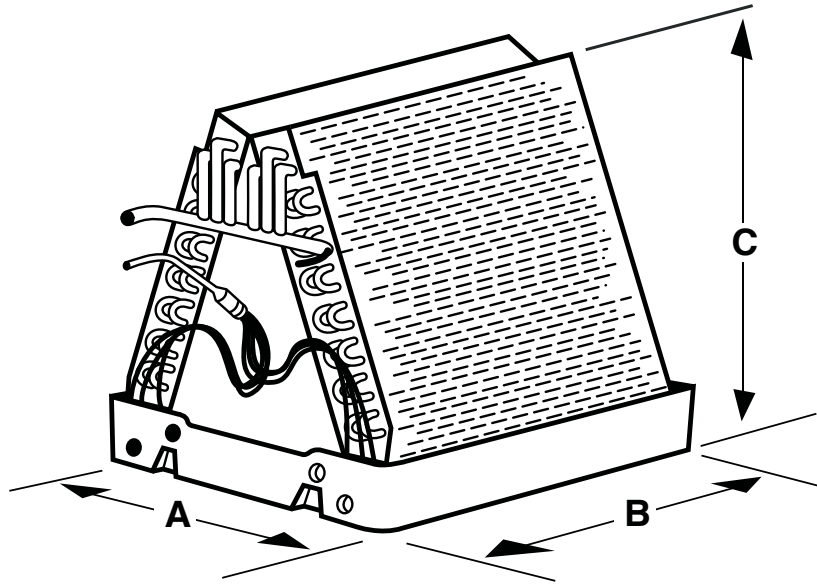

Model	Size (tons)	All Dimensions in Inches				
		A	B	C	Liquid	Suction
ACD024A	2	16 5/8	19	14 1/2	3/8	3/4
ACD036A	3	19 5/8	19	18 1/2	3/8	7/8
ACD048A	4	23 5/8	19	20 1/2	3/8	7/8
ACD060B	5	23 5/8	20 1/2	20 1/2	3/8	7/8

NOTES:

1. The AC series coils are designed as high efficiency "A" coils to be installed on new and existing indoor furnaces. These coils may be used in upflow and downflow applications.
2. Coils are ETL and CSA approved.
3. Primary and secondary drain connections are available on the LH or RH side of the drain pan, and are 3/4" FPT. Center line of drains located from pan corner, 1 1/2" for primary and 3 1/2" for secondary.
4. Drain pan is injection molded high temperature UL approved plastic (Stainless steel on 5 ton DX coil).
5. All coils are equipped with factory-installed TXV, 15% bleed type.

⚠ WARNING ⚠

IF USING A DUAL FUEL APPLICATION, "A" COIL MUST BE INSTALLED ON THE OUTLET OF THE FURNACE. INSTALLATION ON THE RETURN COULD CAUSE FURNACE HEAT EXCHANGER FAILURE, AND MAY VOID FURNACE WARRANTY.

Section 6a: Two-Stage R-410A Split System Compressor Section Unit Electrical Data

Model	Voltage Code	60Hz Power		Compressor		HWG Pump FLA	Ext Loop Pump FLA*	Total Unit FLA	Min Circuit AMPS	Max Fuse HACR	Min AWG	Max Ft
		Volts	Phase	LRA	RLA							
024/026	0	208/230	1	70.0	14.1	N/A	N/A	14.1	17.6	30	N/A	N/A
	1	208/230	1	70.0	14.1	0.5	4.0	18.6	22.1	35	12	53
	8	208/230	1	70.0	14.1	0.5	4.0	18.6	22.1	35	12	53
036/038	0	208/230	1	96.0	16.7	N/A	N/A	16.7	20.9	35	N/A	N/A
	1	208/230	1	96.0	16.7	0.5	4.0	21.2	25.4	40	10	78
	2	208/230	3	88.0	13.5	N/A	N/A	13.5	16.9	30	N/A	N/A
	8	208/230	1	96.0	16.7	0.5	4.0	21.2	25.4	40	10	78
048/050	0	208/230	1	118.0	25.6	N/A	N/A	25.6	32.0	50	N/A	N/A
	1	208/230	1	118.0	25.6	0.5	5.5	31.6	38.0	60	8	81
	2	208/230	3	123.0	17.6	N/A	N/A	17.6	22.0	35	N/A	N/A
	8	208/230	1	118.0	25.6	0.5	5.5	31.6	38.0	60	8	81
060/062	0	208/230	1	150.0	27.2	N/A	N/A	27.2	34.0	60	N/A	N/A
	1	208/230	1	150.0	27.2	0.5	5.5	33.2	40.0	60	8	77
	8	208/230	1	150.0	27.2	0.5	5.5	33.2	40.0	60	8	77

Notes:

1. All line and low voltage wiring must adhere to the National Electrical Code and Local Codes, whichever is the most stringent.
2. Wire length based on a one way measurement with a 2% voltage drop.
3. Wire size based on 60°C copper conductor and minimum circuit ampacity.
3. All fuses class RK-5
4. Min/Max Voltage: 208/230/60/1 = 197/243, 208/230/60/3 = 197/243

* The external loop pump FLA is based on a maximum of three UP26-116F-230V pumps (1/2hp) for 048 - 062 and two pumps for 024 - 038

Section 6b: R-410A Split System Air Handler Section Unit Electrical Data

Model	60 HZ Power		Field-Installed Elect Heat		Motor Amps / HP	Minimum Circuit Ampacity ²	Maximum Fuse Size ²
	Volts	Phase	# Circuits	kW ¹			
024	208/230	1	None	0	2.8 / 0.33	3.5	10
			1	10		54.9	60
036	208/230	1	None	0	4.3 / 0.50	5.4	10
			1	10		56.4	60
			2	15		30.3 / 56.4	40 / 70
042-060	208/230	1	None	0	6.8 / 1.0	8.5	15
			1	10		58.9	70
			2	15		32.8 / 58.9	40 / 70
			2	20		58.9 / 58.9	70 / 70

Notes:

1. Nominal kW at 240V. Derate 25% for 208V.
2. Units with field-installed electric heat 15kW and larger have two circuits. Data shown as "XX/XX" refers to circuit 1 before the "/" and circuit 2 after the "/"
3. Always refer to unit nameplate data prior to installation

Section 6c: Single Stage R-410A Split System Compressor Section Unit Electrical Data

Model	Voltage Code	60Hz Power		Compressor		HWG Pump FLA	Ext Loop Pump FLA*	Total Unit FLA	Min Circuit AMPS	Max Fuse HACR	Min AWG	Max Ft
		Volts	Phase	LRA	RLA							
018	0	208/230	1	48.0	9.0	N/A	N/A	9.0	11.3	20	N/A	N/A
	1	208/230	1	48.0	9.0	0.5	4.0	13.5	15.8	20	12	74
	8	208/230	1	48.0	9.0	0.5	4.0	13.5	15.8	20	12	74
024	0	208/230	1	64.0	12.8	N/A	N/A	12.8	16.0	25	N/A	N/A
	1	208/230	1	64.0	12.8	0.5	4.0	17.3	20.5	30	12	57
	2	208/230	3	63.0	8.3	N/A	N/A	8.3	10.4	15	N/A	N/A
	8	208/230	1	64.0	12.8	0.5	4.0	17.3	20.5	30	12	57
030	0	208/230	1	79.0	16.7	N/A	N/A	16.7	20.9	35	N/A	N/A
	1	208/230	1	79.0	16.7	0.5	4.0	21.2	25.4	40	10	78
	2	208/230	3	73.0	10.4	N/A	N/A	10.4	13.0	20	N/A	N/A
	8	208/230	1	79.0	16.7	0.5	4.0	21.2	25.4	40	10	78
036	0	208/230	1	112.0	17.9	N/A	N/A	17.9	22.4	40	N/A	N/A
	1	208/230	1	112.0	17.9	0.5	4.0	22.4	26.9	40	10	74
	2	208/230	3	88.0	13.5	N/A	N/A	13.5	16.9	30	N/A	N/A
	8	208/230	1	112.0	17.9	0.5	4.0	22.4	26.9	40	10	74
042	0	208/230	1	117.0	21.8	N/A	N/A	21.8	27.3	45	N/A	N/A
	1	208/230	1	117.0	21.8	0.5	5.5	27.8	33.3	50	8	92
	2	208/230	3	83.1	13.7	N/A	N/A	13.7	17.1	30	N/A	N/A
	8	208/230	1	117.0	21.8	0.5	5.5	27.8	33.3	50	8	92
048	0	208/230	1	134.0	26.4	N/A	N/A	26.4	33.0	50	N/A	N/A
	1	208/230	1	134.0	26.4	0.5	5.5	32.4	39.0	60	8	79
	2	208/230	3	123.0	17.6	N/A	N/A	17.6	22.0	35	N/A	N/A
	8	208/230	1	134.0	26.4	0.5	5.5	32.4	39.0	60	8	79
060	0	208/230	1	158.0	30.1	N/A	N/A	30.1	37.6	60	N/A	N/A
	1	208/230	1	158.0	30.1	0.5	5.5	36.1	43.6	70	6	113
	2	208/230	3	155.0	20.5	N/A	N/A	20.5	25.6	45	N/A	N/A
	8	208/230	1	158.0	30.1	0.5	5.5	36.1	43.6	70	6	113
072	0	208/230	1	148.0	32.1	N/A	N/A	32.1	40.1	70	N/A	N/A
	1	208/230	1	148.0	32.1	0.5	5.5	38.1	46.1	70	6	107
	2	208/230	3	149.0	22.4	N/A	N/A	22.4	28.0	50	N/A	N/A
	8	208/230	1	148.0	32.1	0.5	5.5	38.1	46.1	70	6	107

Notes:

1. All line and low voltage wiring must adhere to the National Electrical Code and Local Codes, whichever is the most stringent.
 2. Wire length based on a one way measurement with a 2% voltage drop.
 3. Wire size based on 60°C copper conductor and minimum circuit ampacity.
 3. All fuses class RK-5
 4. Min/Max Voltage: 208/230/60/1 = 197/243, 208/230/60/3 = 197/243
- * The external loop pump FLA is based on a maximum of three UP26-116F-230V pumps (1/2hp) for 042 - 072 and two pumps for 018 - 036.

Section 7: Unit Placement

UNIT PLACEMENT

When installing a geothermal heating and cooling unit, there are several items the installer should consider before placing the equipment.

1. **Service Access.** Is there enough space for service access? A general rule of thumb is at least 2 feet in the front and 2 feet on at least one side.
2. **Unit Air Pad.** All vertical geothermal heating and cooling equipment should be placed on either a formed plastic air pad, or a high density, closed cell polystyrene pad. Downflow units should be placed on a non-combustible base. This helps eliminate vibration noise that could be transmitted through the floor.
3. The installer has verified that all applicable wiring, ductwork, piping, and accessories are correct and on the job site.

PRE-INSTALLATION

Before you fully install the geothermal equipment, it is recommended you go through this quick checklist before placing the equipment.

- Fully inspect the unit after unpacking.
- Open both the air handler section and compressor section and removed any packaging material or documentation included in the unit.
- Remove all packaging materials and ties from the rear of the blower.
- Locate the Unit Start-Up form from this manual and have it available as the unit installation proceeds.

⚠ WARNING ⚠

IF USING A DUAL FUEL APPLICATION, "A" COIL MUST BE INSTALLED ON THE OUTLET OF THE FURNACE. INSTALLATION ON THE RETURN COULD CAUSE FURNACE HEAT EXCHANGER FAILURE, AND MAY VOID FURNACE WARRANTY.

Section 7a: Ductwork Installation

DUCT WORK

All new ductwork shall be designed as outlined in Sheet Metal and Air Conditioning Contractors National Association (SMACNA) or Air Conditioning Contractors of America (ACCA) or American Society of Heating, Refrigerating and Air Conditioning Engineers (ASHRAE) handbooks.

All supply/return plenums should be isolated from the unit by a flexible connector (canvas) or equivalent to prevent transfer of vibration noise to the ductwork. The flex connector should be designed so as not to restrict airflow. Turning vanes should be used on any run over 500 CFM. If the unit is installed in a noninsulated space the metal ductwork should be insulated on the inside with fiberglass insulation or similar insulation to prevent heat loss/gain and to absorb air noise. If the unit is being installed with existing ductwork, the ductwork must be designed to handle the air volume required by the unit being installed. When running a cooling or heating load on a building, size ductwork accordingly to the building design load and heat pump CFM.

Rule of Thumb: When sizing ductwork use 400 CFM per Ton.

As a general rule, maximum recommended face velocity for a supply outlet used in a residential application is 800 FPM. Maximum recommended return grille velocity is 400 FPM. Systems with higher velocity, are likely to have noise problems.

In buildings where ceilings are 8 feet or more, at least 50 percent of the return air should be taken back to the heat pump from the ceiling or high sidewall location and not more than 50 percent from the floor or low sidewall location.

Section 7a: Ductwork Installation

Figure 1: Standard Ductwork Connection Setup

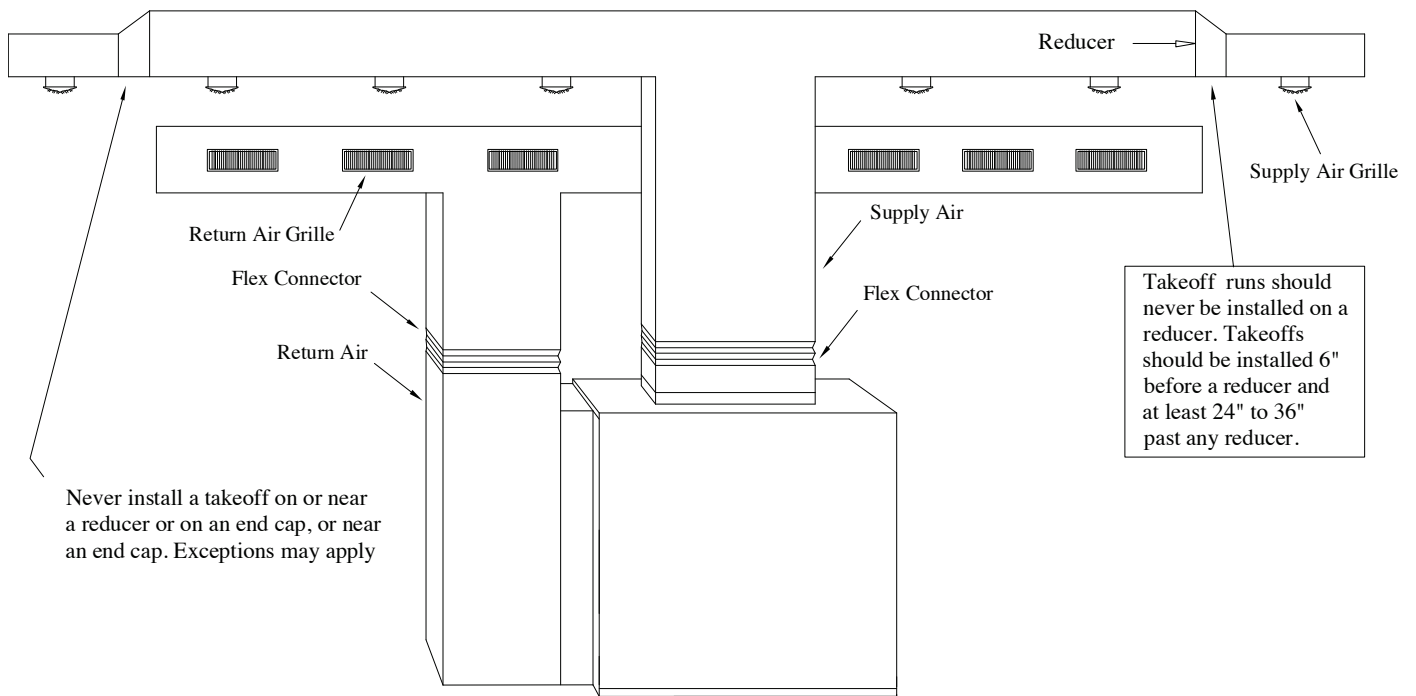

The air handling unit comes with an ECM Motor or PSC 3-speed blower motor. For maximum performance, the blower speed should be set to maintain between 350 and 450 CFM/ton. Changing the wires (for PSC) at the blower will change the blower speed.

Table 1: Maximum Air Velocities

Location	Supply	Return
Main Ducts	900 FPM	600 FPM
Branch Ducts	700 FPM	600 FPM
Grills, Registers, Diffusers	750 FPM	600 FPM

Section 7a: Ductwork Installation

Figure 2: Ductwork with Split Damper Connection Setup

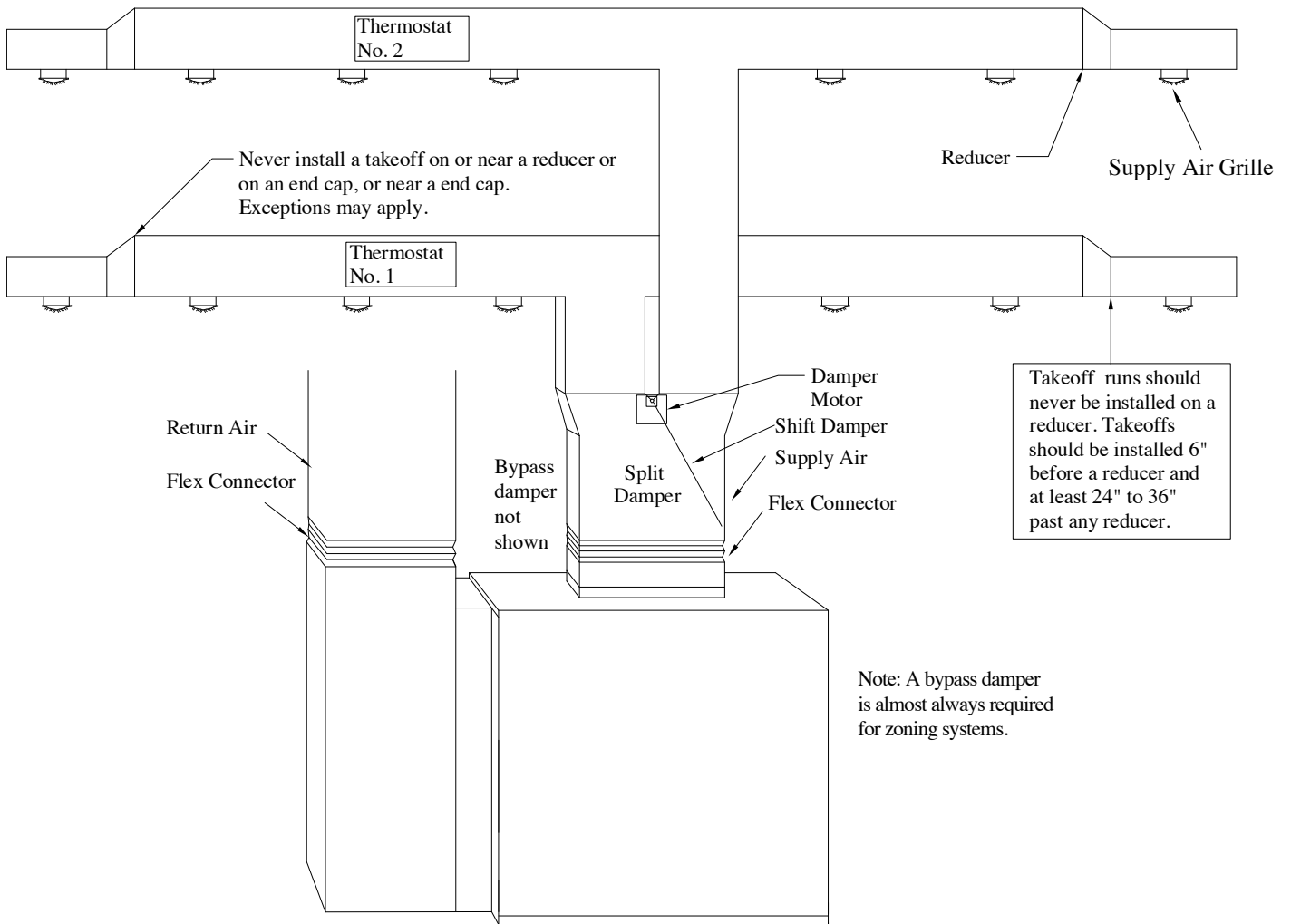

Section 7b: Filter Drier Installation

INSTALLATION

A reversible heat pump filter drier must be installed on the liquid line near the cabinet of the compressor section. A filter drier is furnished with the unit. The filter drier kit includes a 3" piece of 1/2" or 5/8" copper tubing. This tubing will fit either inside or on the outside of the stub coming off the liquid line service valve. Braze it in place. Then braze the filter drier onto it. Make sure the arrow on the filter drier points in the appropriate direction. A second piece of copper is attached between the filter drier and the liquid line (not needed for all applications, depending upon line set size -- consult line set sizing chart).

Refer to the split system I.O.M. (installation, operating, and maintenance) manual for details on line set and unit installation. Always use dry nitrogen when brazing.

Table 2: Recommended Line Set Sizes

Model	Unit Refrigerant Connections		Recommended Liquid & Suction Line Size			
			20 Feet		50 Feet	
	Liquid Line (OD)	Suction Line (OD)	Liquid Line (OD)	Suction Line (OD)	Liquid Line (OD)	Suction Line (OD)
018 - 028	1/2	5/8	3/8	3/4	3/8	3/4
030 - 040	1/2	3/4	3/8	3/4	1/2	7/8
042 - 054	1/2	3/4	1/2	7/8	1/2	1-1/8
060 - 072	5/8	7/8	1/2	7/8	5/8	1-1/8

40°F Evaporating Temperature

Weight of refrigerant in copper lines per 10 feet	
Liquid Line Size (OD)	Oz. Per 10 Feet
3/8"	5.4
1/2"	10.4
5/8"	19.5

Figure 3: Filter Drier Installation

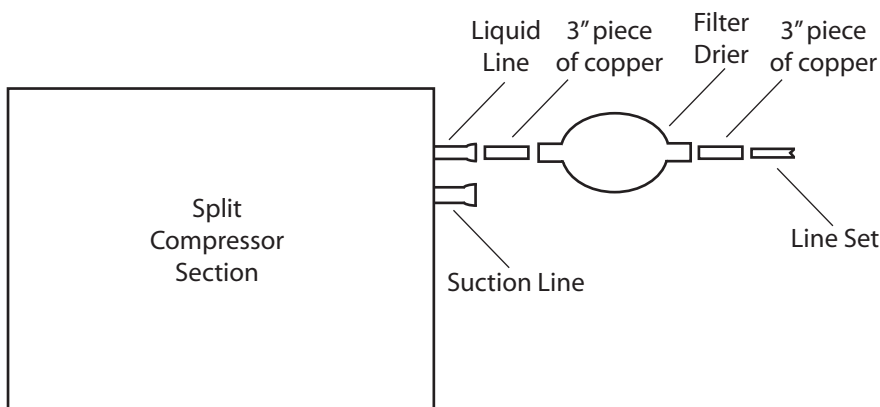

Section 7c: Line Set Installation

INTRODUCTION

The purpose of this section is to help in the design of refrigeration line sets on geothermal heat pump systems. The three considerations when designing a refrigerant piping system are as follows:

1. **System Reliability:** Poor Oil Management may shorten the life of the compressor. Proper liquid refrigerant control is essential.
2. **System Performance:** Pressure drop in refrigerant lines tends to decrease capacity and increase power consumption. High velocities can increase sound levels. Modulation often depends on proper piping.
3. **Cost:** Level of refrigerant, copper piping, accessories, and labor used will impact the applied cost.

DEFINITIONS

Long line set applications are defined as any line set that includes 50 feet or more of interconnecting tubing or a vertical distance between the evaporator and compressor sections exceeding 20 feet.

LINE SET REQUIREMENTS/LIMITATIONS

Line Set Limitations

Up to 50 equivalent feet: Use rated line sizes listed in unit installation instructions.

50 - 75 equivalent feet or 20 feet of vertical separation: Bi-flow liquid line solenoid and crankcase heater required (refer to table 1 and piping diagrams pages 5, 6, & 7).

Maximum Piping Lengths:

Maximum equivalent length = 75 feet
 Maximum linear length = 50 feet
 Maximum linear liquid lift = 50 feet
 Maximum linear vapor rise =
 50 feet (Single Speed)/25 feet (Two Stage)

FITTINGS AND COMPONENTS

All piping should be "ACR" or "L" type copper pipe. Long radius fittings should always be used unless there is not enough physical space. Pressure drop due to friction in pipe, fittings

and field installed accessories such as a drier, solenoid valve or other devices should be considered (see Table 3). The pressure drop due to friction is usually smaller than pressure drop due to lift. The pressure drop ratings of field installed devices are usually supplied by the manufacturer of the device and should be used if available.

Equivalent Length

Valves, fittings, and bends create more friction pressure drop than straight copper piping. Find the equivalent feet of straight tubing for each fitting for calculations. This allows for a quick calculation of the total equivalent length (see Example 1). The equivalent length of copper tubing for commonly used fittings, valves, and filter-drier are shown in Table 3.

Total Equivalent Length = Linear Feet of Straight Tubing + Fitting Losses in Equivalent Feet

Example 1: A 3-ton unit with 7/8" vapor tubing has 50 linear feet of straight tubing. The total number of elbows includes three long radius 90° elbows and five standard 90° elbows.

50ft. of straight tubing
 + 4 standard 90° elbows X 2 equiv ft
 + 1 liquid line solenoid X 12 equiv ft
 + 1 filter-drier X 6 equiv ft
 = 50ft. + 8ft. + 12ft. + 6ft.
 = 76 ft. total equivalent length

Table 3: Copper Fittings in Equivalent Length

Tube Size O.D. (in.)	90° Std A	90° Long Radius - B	45° Std C	45° Long Radius
3/8"	1.2	0.8	0.5	0.3
1/2"	1.3	0.9	0.6	0.4
5/8"	1.6	1.0	0.8	0.5
3/4"	1.8	1.2	0.9	0.6
7/8"	2.0	1.4	1.0	0.7
1-1/8"	2.6	1.7	1.3	0.9
Liquid Line Solenoid	12			
Filter	6			

Section 7c: Line Set Installation

LINE SETS / CHARGING

Vapor Line

A long line set application can critically increase the charge level needed for a system. As a result, the system is very prone to refrigerant migration during its off-cycle. A crankcase heater and bi-flow liquid line solenoid will help minimize this risk. A crankcase heater and bi-flow liquid line solenoid is recommended for any line set over 50 feet in equivalent length or 20 feet of vertical separation. Because oil separates from the refrigerant in the evaporator, the vapor line velocity must be adequate to carry the oil along with the refrigerant. Horizontal vapor lines require a minimum of 800 fpm velocity for oil entrainment. Vapor risers require 1200 fpm minimum, and preferably 1500 fpm regardless of the length of the riser.

NOTE: *When a two-stage compressor section is located above the indoor coil, the maximum vertical rise of a vapor line must not exceed 25 feet. This limit is due to velocity requirements for oil entrainment in the vapor riser.*

For example, a 4 ton unit producing 48,000 Btuh with a 7/8" vapor line has a velocity of 1500 fpm (See Figure 5). On first stage the compressor runs at 67% or 32,680 Btuh and has a velocity of less than 1200 fpm per the pressure drop chart. In order to achieve velocity up to 1500 fpm in first stage, the line would have to be 3/4". The pressure drop for 48,000 Btuh would be over 9 psi. A system will lose approximately 1% capacity for every pound of pressure drop due to friction in the suction line. This 1% factor is used to estimate the capacity loss of refrigerant lines. Due to the low velocities created in the vapor line in first stage, a two stage unit vapor line should not be increased from the pipe size at the compressor section.

For all vapor line trapping see Figure 4 below. Remember to add all the fittings into the total equivalent length of the vapor line.

Liquid Line

Pressure drop due to vertical liquid lift must be considered. The pressure drop for vertical lift is 0.5 pound per foot for R22 and 0.43 pound per foot for R-410A. This is usually large and may be a limiting factor in the ultimate design of the system. Next, the pressure entering the expansion device must be sufficient to produce the required flow through the expansion device. A pressure drop of 100 psi for R22 (175 psi for R-410A) across the expansion valve and distributor is necessary to produce full refrigerant flow at rated capacity. Therefore, it is necessary for liquid refrigerant (free of flash gas) to be delivered to the expansion valve. Longer line sets may require a larger liquid line due to the higher pressure drops of smaller diameter tubing. Reference the Installation Manual for recommended liquid line sizes for each unit. Even liquid lines on two stage units can be increased because velocities required for oil return are not critical in the liquid line.

Figure 4: Oil Trap Construction

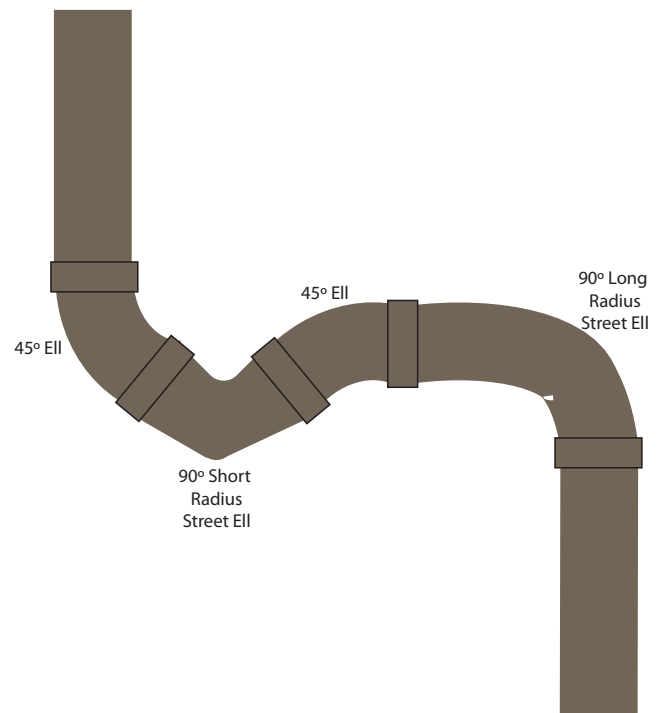

Section 7c: Line Set Installation

Figure 5: Refrigerant R-410A Suction Line Pressure Drop/Velocity per 100 ft. of Line at 45°F Evaporating Temperature and 125°F Condensing Temperature

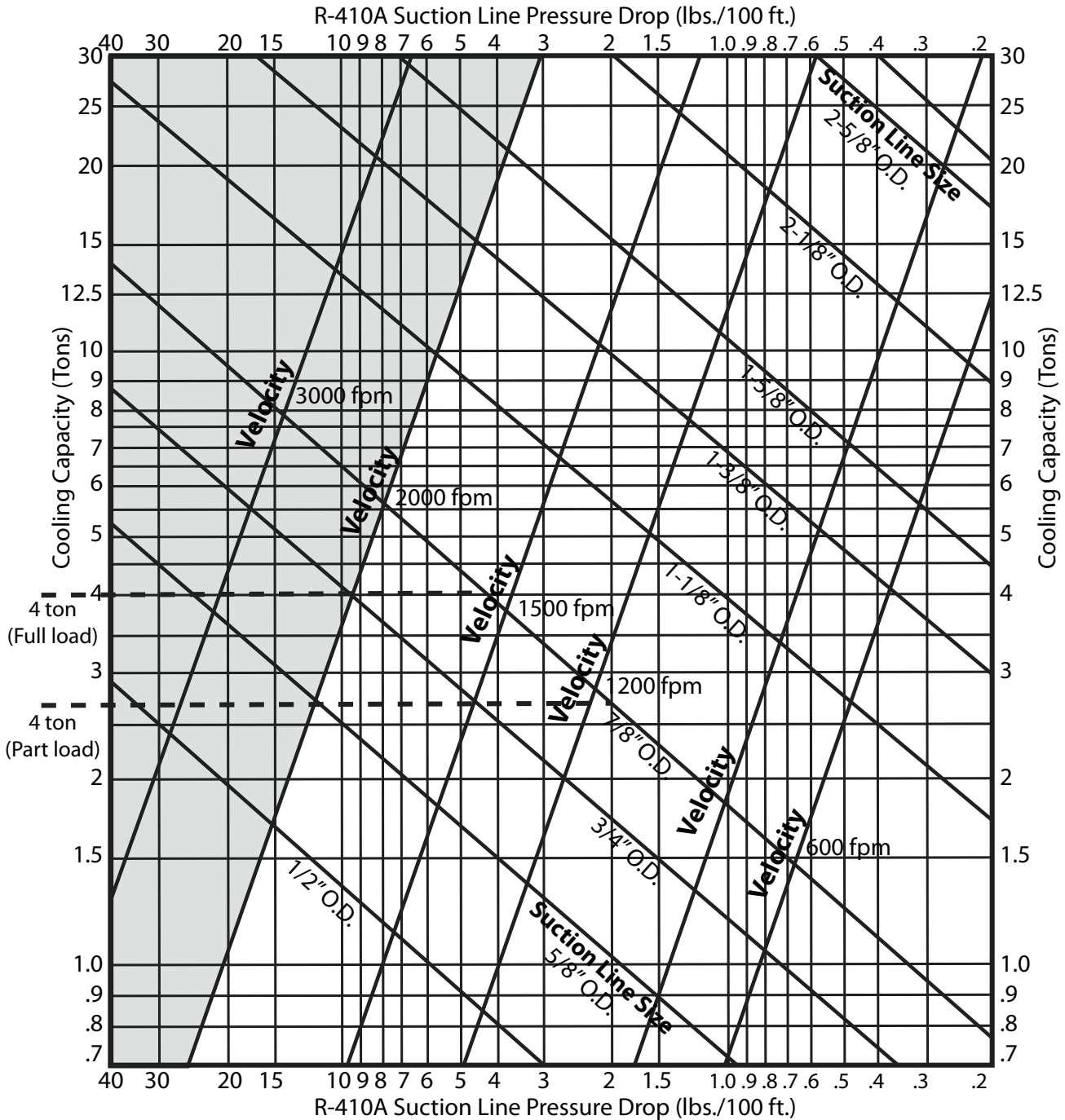

To use this chart, first find capacity (tons) on the left side of the chart. To find pipe size, proceed right to the smallest pipe size. Pressure drop (vertical line) and velocity (diagonal lines) can then be determined for the pipe size selected. For example, for a 4 ton unit, select 7/8" O.D. line.
 NOTE: Shaded area denotes unacceptable velocity range.

Section 7c: Line Set Installation

GEOTHERMAL REFRIGERATION CIRCUITS

Bi-Flow Liquid Line Solenoid Valve

In order to minimize off-cycle refrigerant migration to the compressor, a bi-flow liquid line solenoid is required for all long line set heat pump applications. The Bi-flow solenoid valve controls the flow of refrigerant only in the direction of the arrow molded into the valve.

The arrow should be positioned toward the compressor section to minimize the transfer of liquid directly into the coax in the heating mode. The solenoid should be installed right after the filter-drier or within two feet of the compressor section.

Charging Information

Since the lengths of line sets vary, it is necessary to calculate additional refrigerant charge. Compressor sections do not have additional charge for the line set. Each foot of liquid line and vapor length requires the amount of refrigerant designated in Table 4. Also, long line applications require a minimum of 10 degrees subcooling to prevent any refrigerant flashing before the thermostatic expansion valve. The subcooling and superheat should be checked in both modes of operation. Refer to the operating pressure chart in the Specifications manual for the correct superheat.

PIPING DIAGRAMS

The piping diagrams on the following pages illustrate considerations for applications of a solenoid valve, traps, and piping based upon the location of the compressor section and air handler.

Table 4: Refrigerant Weight

Weight of Refrigerant in Copper Tubing Per Foot (in Ounces)		
O.D. (in.)	Liquid Line	Suction (Vapor) Line
3/8"	0.54	
1/2"	1.04	
5/8"	1.95	0.07
3/4"		0.10
7/8"		0.13
1-1/8"		0.21

Section 7c: Line Set Installation

Figure 6: Air handler section above compressor section

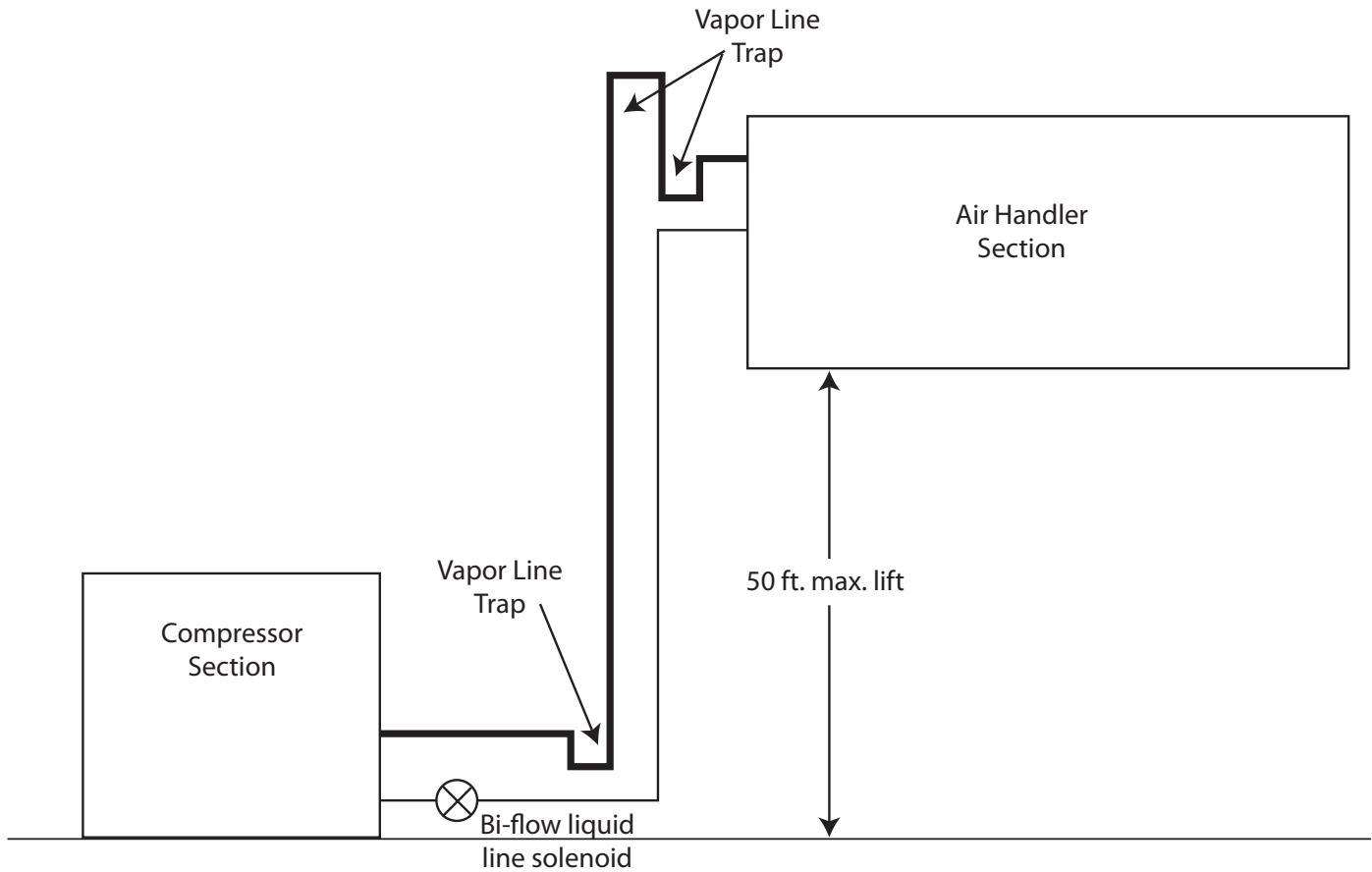

Notes:

- Crankcase heater (Copeland Part #: 018-0073-00) and Bi-flow liquid line solenoid (Emerson Part Numbers: 200RB4T3 – 3/8"; 200RB5T4 – 1/2"; 200RB6T5 – 5/8") required if total equivalent length is greater than or equal to 50 feet or the vertical separation is greater than or equal to 20 feet.
- An inverted vapor line trap must be installed with the top of the trap above the evaporator section.
- P-traps should be installed at the outlet of the evaporator section and at the bottom of vapor line drop.
- 75 feet maximum equivalent line length
- 50 feet maximum vertical separation
- Vapor Line sizes on Two-stage units should not be increased due to the velocity requirements for returning oil to the compressor.

Section 7c: Line Set Installation

Figure 7: Compressor section above air handler section

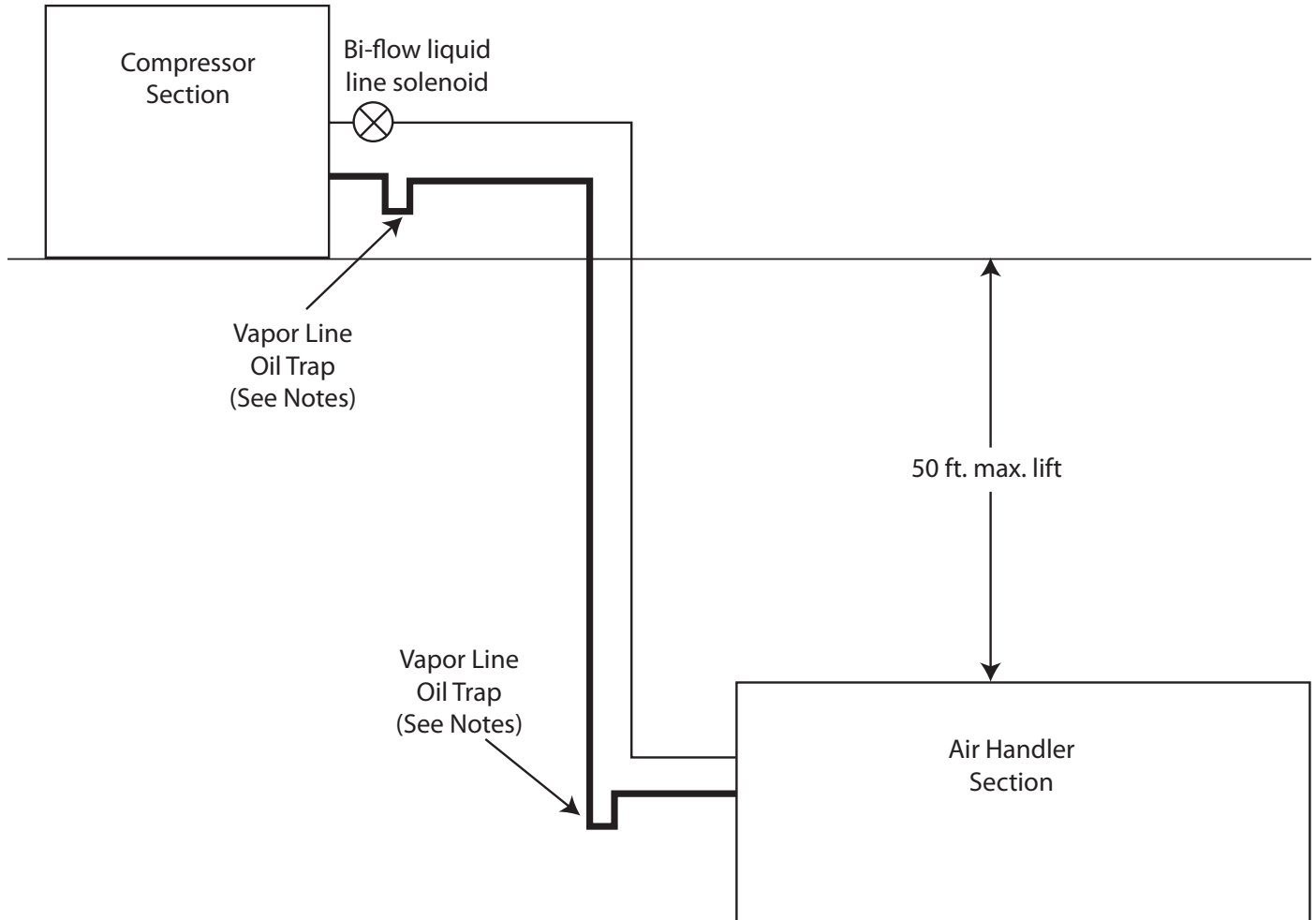

Notes:

- Crankcase heater (Copeland Part #: 018-0073-00) and Bi-flow liquid line solenoid (Emerson Part Numbers: 200RB4T3 – 3/8"; 200RB5T4 – 1/2"; 200RB6T5 – 5/8") required if total equivalent length is greater than or equal to 50 feet or the vertical separation is greater than or equal to 20 feet.
- A P-trap should be installed at the outlet of the evaporator section.
- If vertical separation is greater than or equal to 50 feet a second trap should be installed at the 50 feet mark.
- 75 feet maximum equivalent line length
- 50 feet maximum vertical separation
- Vapor Line sizes on Two-stage units should not be increased due to the velocity requirements for returning oil to the compressor.
- Two-stage units should have a maximum of 25 feet of vertical lift on the vapor line.

Section 7c: Line Set Installation

Figure 8: Horizontal piping above air handler section

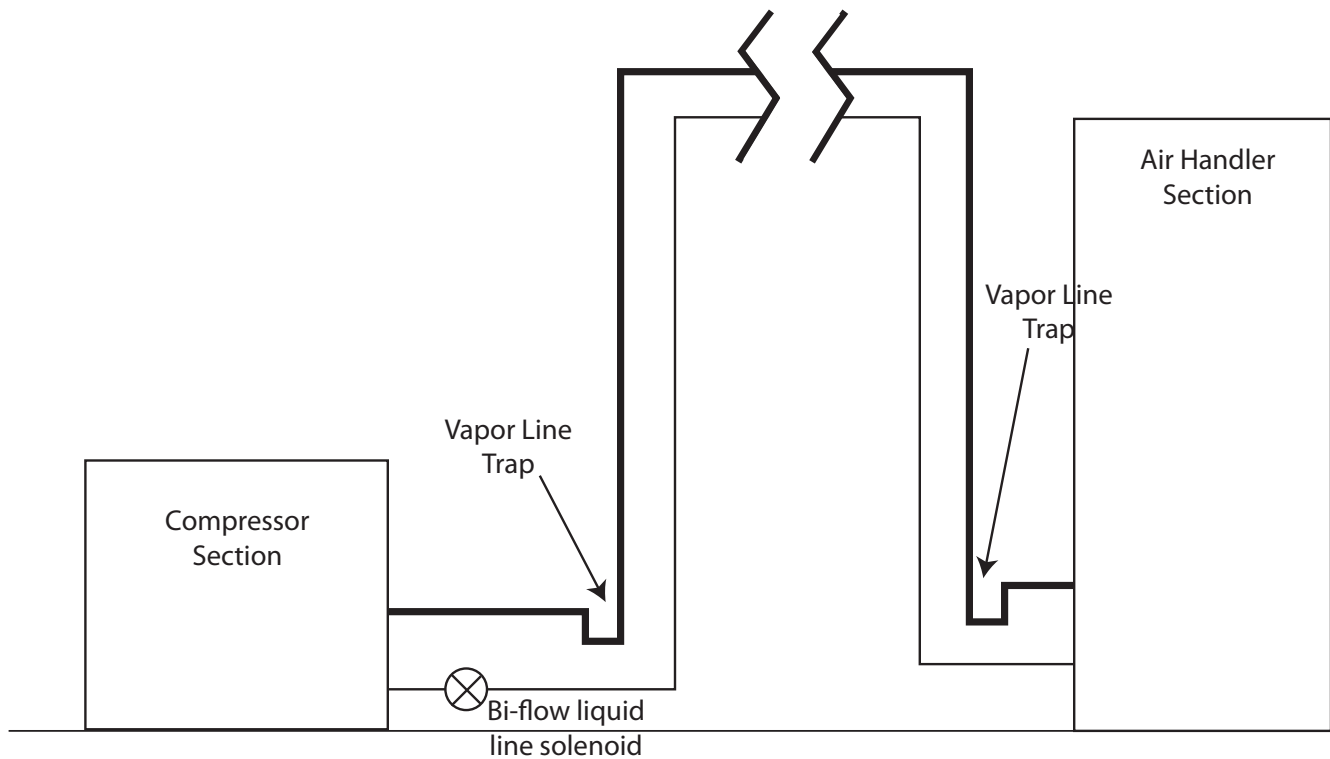

Notes:

- Crankcase heater (Copeland Part #: 018-0073-00) and Bi-flow liquid line solenoid (Emerson Part Numbers: 200RB4T3 – 3/8"; 200RB5T4 – 1/2"; 200RB6T5 – 5/8") required if total equivalent length is greater than or equal to 50 feet or the vertical separation is greater than or equal to 20 feet.
- The vapor line must be installed with the horizontal run higher than the top of the evaporator section.
- P-traps should be installed at the outlet of the evaporator section and at the bottom of vapor line drop.
- 75 feet maximum equivalent line length
- 50 feet maximum vertical separation
- Vapor Line sizes on Two-stage units should not be increased due to the velocity requirements for returning oil to the compressor.

Section 7c: Line Set Installation

Figure 9: Horizontal piping above "A" coil

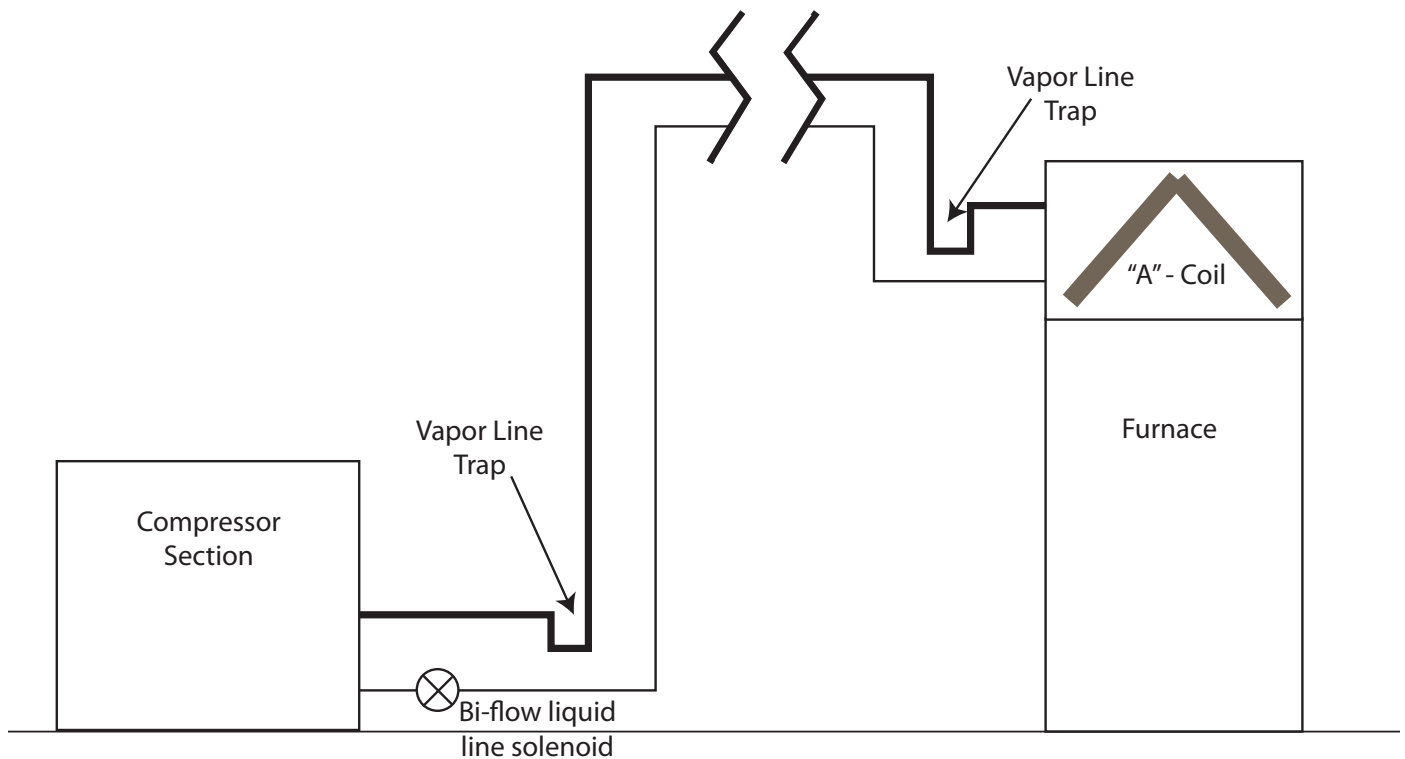

Notes:

- Crankcase heater (Copeland Part #: 018-0073-00) and Bi-flow liquid line solenoid (Emerson Part Numbers: 200RB4T3 – 3/8"; 200RB5T4 – 1/2"; 200RB6T5 – 5/8") required if total equivalent length is greater than or equal to 50 feet or the vertical separation is greater than or equal to 20 feet.
- The vapor line must be installed with the horizontal run higher than the top of the evaporator section.
- P-traps should be installed at the outlet of the evaporator section and at the bottom of vapor line drop.
- 75 feet maximum equivalent line length
- 50 feet maximum vertical separation
- Vapor Line sizes on Two-stage units should not be increased due to the velocity requirements for returning oil to the compressor.

⚠ WARNING ⚠

IF USING A DUAL FUEL APPLICATION, "A" COIL MUST BE INSTALLED ON THE OUTLET OF THE FURNACE. INSTALLATION ON THE RETURN COULD CAUSE FURNACE HEAT EXCHANGER FAILURE, AND MAY VOID FURNACE WARRANTY.

Section 8: Unit Piping Installation

Open Loop Piping

Placement of the components for an open loop system are important when considering water quality and long term maintenance. The water solenoid valve should always be placed on the outlet of the heat pump, which will keep the heat exchanger under pressure when the unit is not operating. If the heat exchanger is under pressure, minerals will stay in suspension. Water solenoid valves are also designed to close against the pressure, not with the pressure. Otherwise, they tend to be noisy when closing.

A flow regulator should be placed after the water solenoid valve. Always check the product specification catalog for proper flow rate. A calculation must be made to determine the flow rate, so that the leaving water temperature does not have the possibility of freezing.

Other necessary components include a strainer, boiler drains for heat exchanger flushing, P/T ports and ball valves. Ball valves allow the water to be shut off for service, and also help when velocity noise is noticeable through the flow regulator. Spreading some of the pressure drop across the ball valves will lessen the

velocity noise. Always double check flow rate at the P/T ports to make sure the ball valve adjustments have not lowered water flow too much, and essentially taken the flow regulator out of the equation. It's a good idea to remove the ball valve handles once the system is completed to avoid nuisance service calls.

Hose kits are optional, but make for an easier installation, since the P/T ports and connections are included. The hose also helps to isolate the heat pump from the piping system.

Two-stage units typically include two water solenoid valves, since the heat pump can operate at lower water flow on first stage, saving water. The flow regulators should be sized so that when one valve is open the unit operates at first stage flow rate, and when both valves are open, the unit operates at full load flow rate. For example, a 4 ton unit needs approximately 4 GPM on first stage, and approximately 7 GPM at full load. The flow regulator after the first valve should be 4 GPM, and the flow regulator after the second valve should be 3 GPM. When both valves are open, the unit will operate at 7 GPM.

Figure 10: Open Loop Piping Example

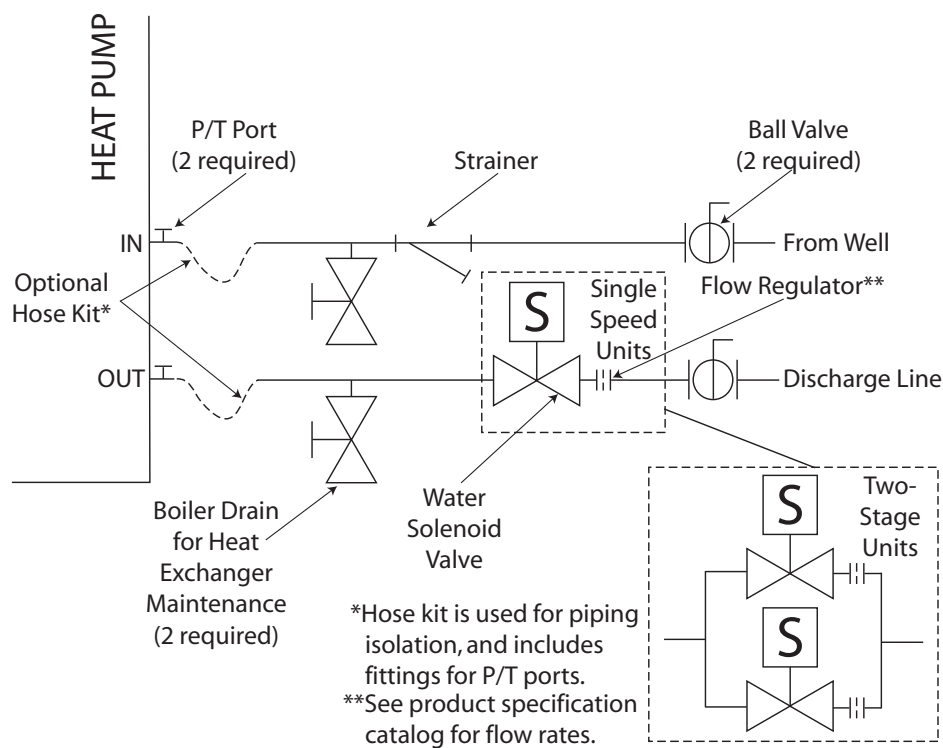

Section 8: Unit Piping Installation

Water Quality

The quality of the water used in geothermal systems is very important. In closed loop systems the dilution water (water mixed with antifreeze) must be of high quality to ensure adequate corrosion protection. Water of poor quality contains ions that make the fluid "hard" and corrosive. Calcium and magnesium hardness ions build up as scale on the walls of the system and reduce heat transfer. These ions may also react with the corrosion inhibitors in glycol based heat transfer fluids, causing them to precipitate out of solution and rendering the inhibitors ineffective in protecting against corrosion. In addition, high concentrations of corrosive ions, such as chloride and sulfate, will eat through any protective layer that the corrosion inhibitors form on the walls of the system.

Ideally, de-ionized water should be used for dilution with antifreeze solutions since de-

ionizing removes both corrosive and hardness ions. Distilled water and zeolite softened water are also acceptable. Softened water, although free of hardness ions, may actually have increased concentrations of corrosive ions and, therefore, its quality must be monitored. It is recommended that dilution water contain less than 100 PPM calcium carbonate or less than 25 PPM calcium plus magnesium ions; and less than 25 PPM chloride or sulfate ions.

In an open loop system the water quality is of no less importance. Due to the inherent variation of the supply water, it should be tested prior to making the decision to use an open loop system. Scaling of the heat exchanger and corrosion of the internal parts are two of the potential problems. The Department of Natural Resources or your local municipality can direct you to the proper testing agency. Please see Table 5 for guidelines.

Table 5: Water Quality

Potential Problem	Chemical(s) or Condition	Range for Copper Heat Exchangers	Range for Cupro-Nickel Heat Exchangers
Scaling	Calcium & Magnesium Carbonate	Less than 350 ppm	Less than 350 ppm
Corrosion	pH Range	7 - 9	5 - 9
	Total Dissolved Solids	Less than 1000 ppm	Less than 1500 ppm
	Ammonia, Ammonium Hydroxide	Less than 0.5 ppm	Less than 0.5 ppm
	Ammonium Chloride, Ammonium Nitrate	Less than 0.5 ppm	Less than 0.5 ppm
	Calcium Chloride / Sodium Chloride	Less than 125 ppm	Less than 125 ppm - Note 4
	Chlorine	Less than 0.5 ppm	Less than 0.5 ppm
Biological Growth	Hydrogen Sulfide	None Allowed	None Allowed
	Iron Bacteria	None Allowed	None Allowed
	Iron Oxide	Less than 1 ppm	Less than 1 ppm
Erosion	Suspended Solids	Less than 10 ppm	Less than 10 ppm
	Water Velocity	Less than 8 ft/s	Less than 12 ft/s

Notes:

1. Hardness in ppm is equivalent to hardness in mg/l
2. Grains/gallon = ppm divided by 17.1
3. Copper and cupro-nickel heat exchangers are not recommended for pool applications for water outside the range of the table. Secondary heat exchangers are required for applications not meeting the requirements shown above.
4. Saltwater applications (approx. 25,000 ppm) require secondary heat exchangers due to copper piping between the heat exchanger and the unit fittings.

Section 8: Unit Piping Installation

Interior Piping

All interior piping must be sized for proper flow rates and pressure loss. Insulation should be used on all inside piping when minimum loop temperatures are expected to be less than 50°F. Use the table below for insulation sizes with different pipe sizes. All pipe insulation should be a closed cell and have a minimum wall thickness of 3/8". All piping insulation should be glued and sealed to prevent condensation and dripping. Interior piping may consist of the following materials: HDPE, copper, brass, or rubber hose (hose kit only). **PVC is not allowed on pressurized systems.**

Table 6: Pipe Insulation

Piping Material	Insulation Description
1" IPS Hose	1-3/8" ID - 3/8" Wall
1" IPS PE	1-1/4" ID - 3/8" Wall
1-1/4" IPS PE	1-5/8" ID - 3/8" Wall
2" IPS PD	2-1/8" ID - 3/8" Wall

Typical Pressurized Flow Center Installation

The flow centers are insulated and contain all flushing and circulation connections for residential and light commercial earth loops that require a flow rate of no more than 20 gpm. 1-1/4" fusion x 1" double o-ring fittings (AGA6PES) are furnished with the double o-ring flow centers for HDPE loop constructions. Various fittings are available for the double o-ring flow centers for different connections. See table 1 for connection options. A typical installation will require the use of a hose kit. Matching hose kits come with double o-ring adapters to transition to 1" hose connection.

Note: Threaded flow centers all have 1" FPT connections. Matching hose kits come with the AGBA55 adapter needed to transition from 1" FPT to 1" hose.

Figure 11: Typical Single Unit Piping Connection (Pressurized Flow Center)

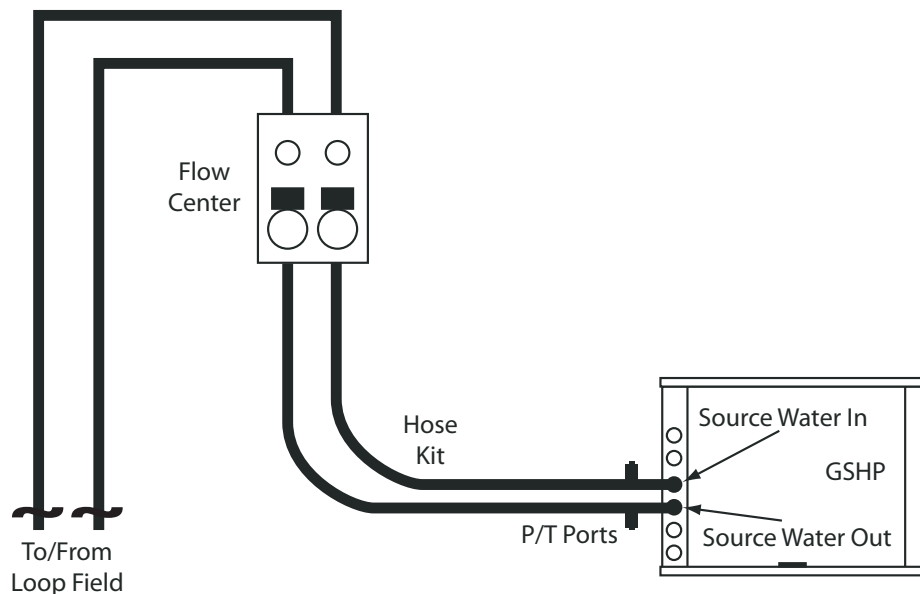

Section 8: Unit Piping Installation

Typical Non-Pressurized Flow Center Installation

Standing column flow centers are designed to operate with no static pressure on the earth loop. The design is such that the column of water in the flow center is enough pressure to prime the pumps for proper system operation and pump reliability. The flow center does have a cap/seal, so it is still a closed system, where the fluid will not evaporate. If the earth loop header is external, the loop system will still need to be

flushed with a purge cart. The non-pressurized flow center needs to be isolated from the flush cart during flushing because the flow center is not designed to handle pressure. Since this is a non-pressurized system, the interior piping can incorporate all the above-mentioned pipe material options (see interior piping), including PVC. The flow center can be mounted to the wall with the included bracket or mounted on the floor as long as it is properly supported.

Figure 12: Typical Single Unit Piping Connection (Non-Pressurized Flow Center)

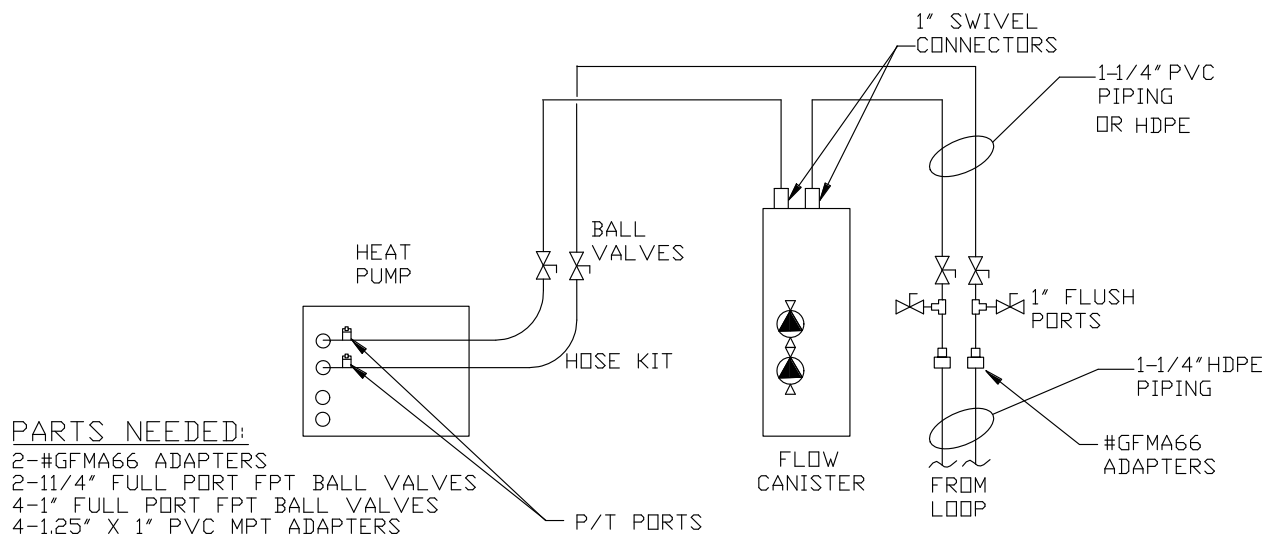

Section 8: Unit Piping Installation

Condensation Drain Connection

Connect the EZ-Trap to the condensate drain on the equipment drain connection. The condensation line must be trapped a minimum of 1.0" as shown on diagram. The condensation line should be pitched away from the unit a minimum of 1/8" per foot. The top of trap must be below the drain connection. For more information on installing EZ-Trap, see installation sheet that comes with the EZ-Trap Kit.

Note: Connect the drain through the trap to the condensation drain system in conformance to local plumbing codes.

Part Number	Description
ACDT1A	EZ-Trap 3/4" Kit
ACDT2A	EZ-Trap 1" Kit

Figure 13: Condensation Drain Connection

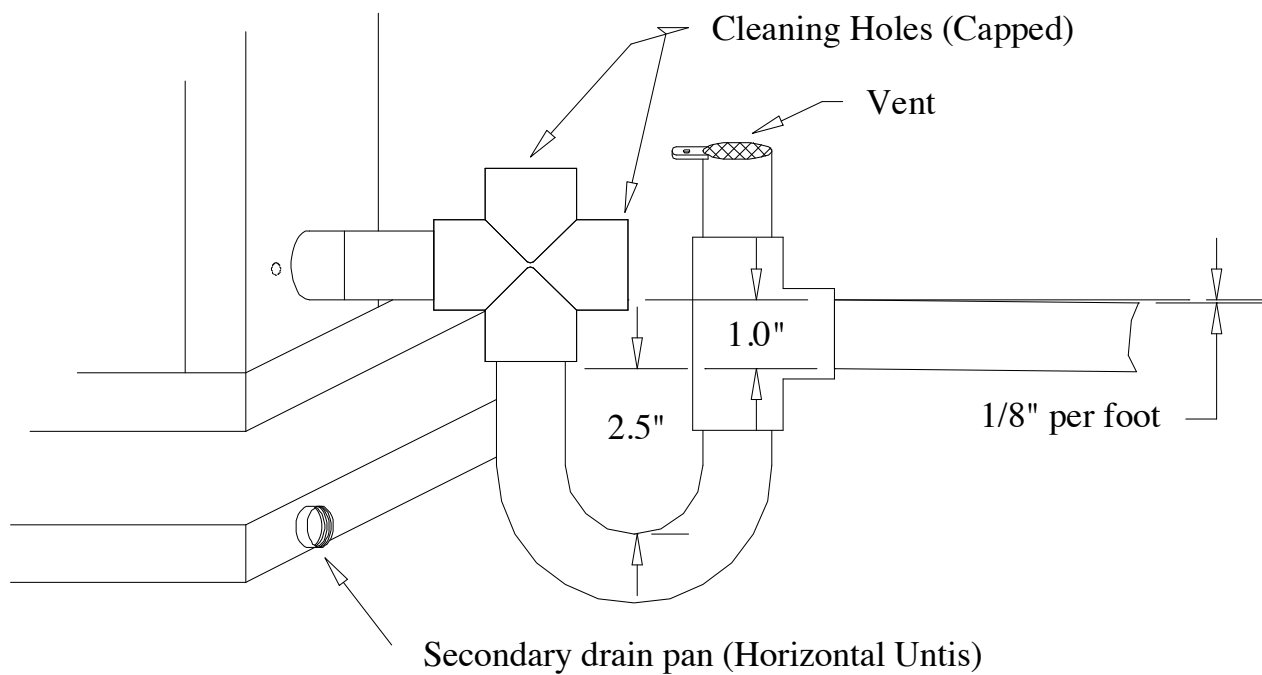

Section 9: Antifreeze

Antifreeze Overview

In areas where minimum entering loop temperatures drop below 40°F, or where piping will be routed through areas subject to freezing, antifreeze is required. Alcohols and glycols are commonly used as antifreeze. However, local and state/provincial codes supersede any instructions in this document. The system needs antifreeze to protect the coaxial heat exchanger from freezing and rupturing. Freeze protection should be maintained to 15°F below the lowest expected entering loop temperature. For example, if 30°F is the minimum expected entering loop temperature, the leaving loop temperature could be 22 to 25°F. Freeze protection should be set at 15°F (30-15 = 15°F). To determine antifreeze requirements, calculate how much volume the system holds. Then, calculate how much antifreeze will be needed by determining the percentage of antifreeze required for proper freeze protection. See Tables 3 and 4 for volumes and percentages. The freeze protection should be checked during installation using the proper hydrometer to measure the specific gravity and freeze protection level of the solution.

Antifreeze Characteristics

Selection of the antifreeze solution for closed loop systems require the consideration of many important factors, which have long-term implications on the performance and life of the equipment. Each area of concern leads to a different "best choice" of antifreeze. *There is no "perfect" antifreeze.* Some of the factors to consider are as follows (Brine = antifreeze solution including water):

Safety: The toxicity and flammability of the brine (especially in a pure form).

Cost: Prices vary widely.

Thermal Performance: The heat transfer and viscosity effect of the brine.

Corrosiveness: The brine must be compatible with the system materials.

Stability: Will the brine require periodic change out or maintenance?

Convenience: Is the antifreeze available and easy to transport and install?

Codes: Will the brine meet local and state/provincial codes?

The following are some general observations about the types of brines presently being used:

Methanol: Wood grain alcohol that is considered toxic in pure form. It has good heat transfer, low viscosity, is non-corrosive, and is mid to low price. The biggest down side is that it is flammable in concentrations greater than 25%.

Ethanol: Grain alcohol, which by the ATF (Alcohol, Tobacco, Firearms) department of the U.S. government, is required to be denatured and rendered unfit to drink. It has good heat transfer, mid to high price, is non-corrosive, non-toxic even in its pure form, and has medium viscosity. It also is flammable with concentrations greater than 25%. Note that the brand of ethanol is very important. Make sure it has been formulated for the geothermal industry. Some of the denaturants are not compatible with HDPE pipe (for example, solutions denatured with gasoline).

Propylene Glycol: Non-toxic, non-corrosive, mid to high price, poor heat transfer, high viscosity when cold, and can introduce micro air bubbles when adding to the system. It has also been known to form a "slime-type" coating inside the pipe. Food grade glycol is recommended because some of the other types have certain inhibitors that react poorly with geothermal systems. A 25% brine solution is a minimum required by glycol manufacturers, so that bacteria does not start to form.

Ethylene Glycol: Considered toxic and is not recommended for use in earth loop applications.

GS4 (POTASSIUM ACETATE): Considered highly corrosive (especially if air is present in the system) and has a very low surface tension, which causes leaks through most mechanical fittings. This brine is not recommended for use in earth loop applications.

Section 9: Antifreeze

Notes:

1. Consult with your representative or distributor if you have any questions regarding antifreeze selection or use.
2. All antifreeze suppliers and manufacturers recommend the use of either de-ionized or distilled water with their products.

Antifreeze Charging

Calculate the total amount of pipe in the system and use Table 7 to calculate the amount of volume for each specific section of the system. Add the entire volume together, and multiply that volume by the proper antifreeze percentage needed (Table 8) for the freeze protection required in your area. Then, double check calculations during installation with the proper hydrometer and specific gravity chart (Figure 14) to determine if the correct amount of antifreeze was added.

Table 7: Pipe Fluid Volume

Type	Size	Volume Per 100ft US Gallons
Copper	1" CTS	4.1
Copper	1.25" CTS	6.4
Copper	1.5" CTS	9.2
HDPE	.75 SDR11	3.0
HDPE	1" SDR11	4.7
HDPE	1.25" SDR11	7.5
HDPE	1.5: SDR11	9.8
HDPE	2" SDR11	15.4

Additional component volumes:

Unit coaxial heat exchanger = 1 Gallon

Flush Cart = 8-10 Gallons

10' of 1" Rubber Hose = 0.4 Gallons

⚠ CAUTION ⚠

Use extreme care when opening, pouring, and mixing flammable antifreeze solutions. Remote flames or electrical sparks can ignite undiluted antifreezes and vapors. Use only in a well ventilated area. Do not smoke when handling flammable solutions. Failure to observe safety precautions may result in fire, injury, or death. Never work with 100% alcohol solutions.

Section 9: Antifreeze

Table 8: Antifreeze Percentages by Volume

Type of Antifreeze	Minimum Temperature for Freeze Protection			
	10°F (-12.2°C)	15°F (-9.4°C)	20°F (-6.7°C)	25°F (-3.9°C)
ProCool (Ethanol)	25%	22%	17%	12%
Methanol	25%	21%	16%	10%
Propylene Glycol	38%	30%	22%	15%

All antifreeze solutions are shown in pure form - not premixed

NOTE: Most manufacturers of antifreeze solutions recommend the use of de-ionized water. Tap water may include chemicals that could react with the antifreeze solution.

Figure 14: Antifreeze Specific Gravity

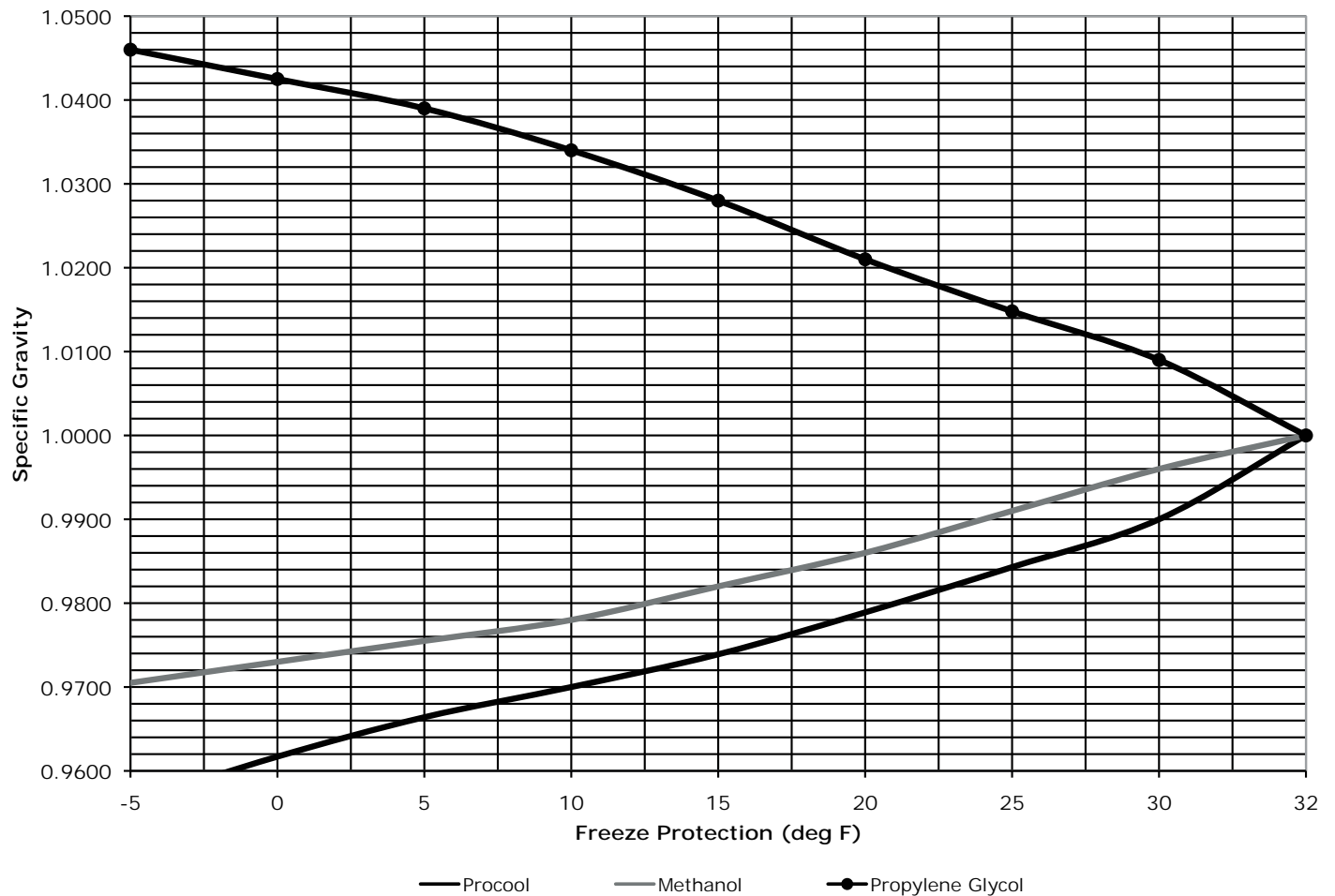

Section 10: Desuperheater Installation

Desuperheater Installation

Units that ship with the desuperheater function also ship with a connection kit.

Note: Desuperheater capacity is based on 0.4 GPM Flow per nominal ton at 90°F entering hot water temperature.

Note: Units that are shipped with a desuperheater do not have the desuperheater pump wires connected to the electrical circuit, to preclude accidentally running the pump while dry. Pump has to be connected to the electric circuit (master contactor) when the lines from the water heater are installed & air is removed.

CONTENTS OF THE DESUPERHEATER FITTING KIT:

- (1) p/n 23-23-0024-001, Installation Instructions
- (1) p/n 11-08-0004-001, 3/4"x 3/4"x 3/4" FPT Brass Tee
- (1) p/n 11-08-0003-001, 3/4" Boiler Drain Valve
- (1) p/n 11-08-0005-001, 3/4" MPT x 3-1/2" Brass Nipple
- (3) p/n 11-08-0006-001, 1/2" SWT x 3/4" MPT Copper Adaptor
- (1) p/n 11-08-0007-001, 3/4" x 3/4" x 1/2" SWT Copper Tee

Plumbing Installation

NOTE: All plumbing and piping connections must comply with local plumbing codes.

TIP: Measure the distance above the floor or shelf that the water heater is setting on, to where the drain valve is located. This distance must be greater than one-half the width of the tee you're about to install, or you won't be able to thread the tee on to the water heater.

Note: Copper is the only approved material for piping the desuperheater.

1. Disconnect electricity to water heater.
2. Turn off water supply to water heater.
3. Drain water heater. Open pressure relief valve.
4. Remove drain valve and fitting from water heater.
5. Thread the 3/4" MPT x 3-1/2" nipple into the water heater drain port. Use Teflon tape, or pipe dope on threads.
6. Thread the center port of the 3/4" brass tee to the other end of the nipple.
7. Thread one of the copper adaptors into the end of the tee closest to the heat pump.
8. Thread the drain valve into the other end of the nipple. See Figure 15.
9. Above the water heater, cut the incoming cold water line. Remove a section of that line to enable the placement of the copper tee.
10. Insert the copper tee in the cold water line. See Figure 16.
11. Thread the remaining two 1/2" SWT x 3/4" MPT copper adaptors into the 3/4" FPT fittings on the heat pump, marked HOT WATER IN and HOT WATER OUT.
12. Run interconnecting 1/2" copper pipe from the HOT WATER OUT on the heat pump, to the copper adaptor located on the tee at the bottom of the water heater (Step 7).
13. Run interconnecting 1/2" copper pipe from the HOT WATER IN on the heat pump, to the copper tee in the cold water line (Step 10).
14. Install an air vent fitting at the highest point of the line from step 13 (assuming it's the higher of the two lines from the heat pump to the water heater). See Figure 16.
15. Turn the water supply to the water heater on. Fill water heater.

Section 10: Desuperheater Installation

16. Flush the interconnecting lines, and check for leaks.
17. Install 3/8" closed cell insulation on the lines connecting the heat pump to the water heater.
18. Reconnect electricity to water heater.

Figure 15: Water Heater Connection Kit Assembly for Bottom of Water Heater

NOTE: Drawing shown vertically for detail. Fitting installs horizontally into hot water tank.

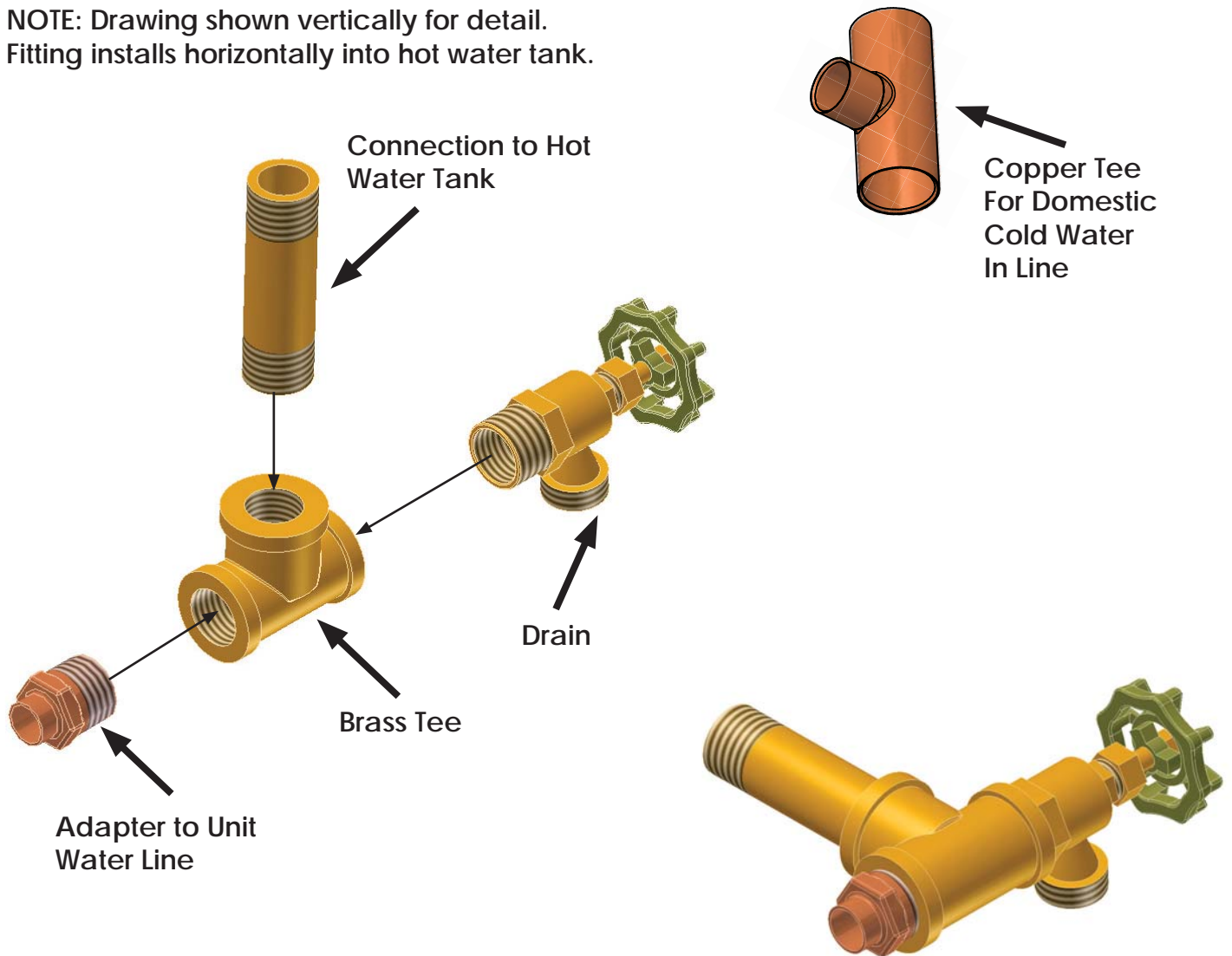

Section 10: Desuperheater Installation

Figure 16: Typical Desuperheater Installation

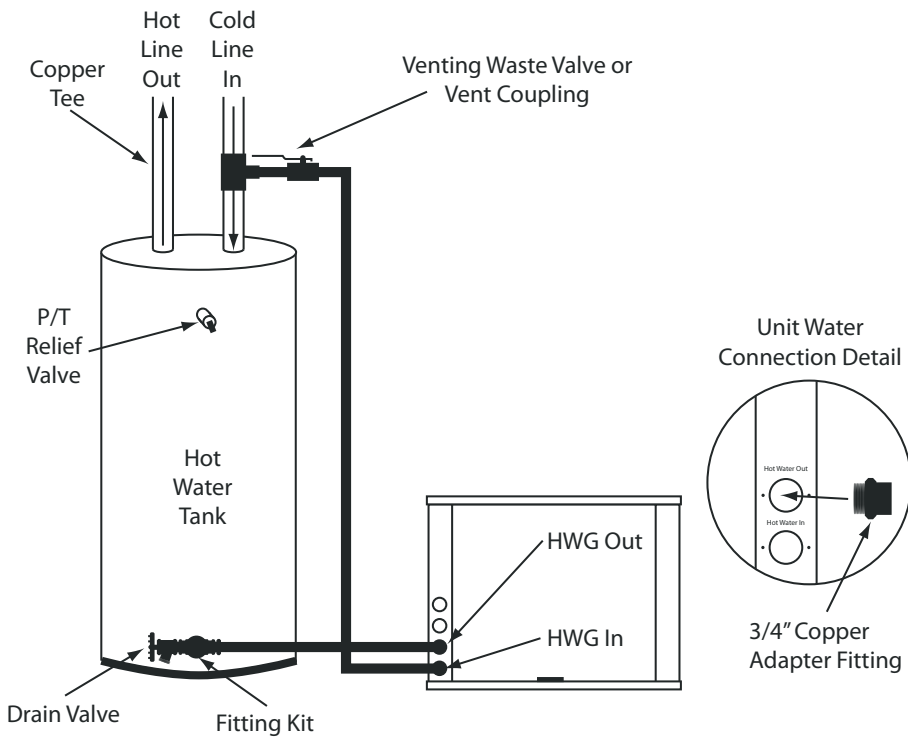
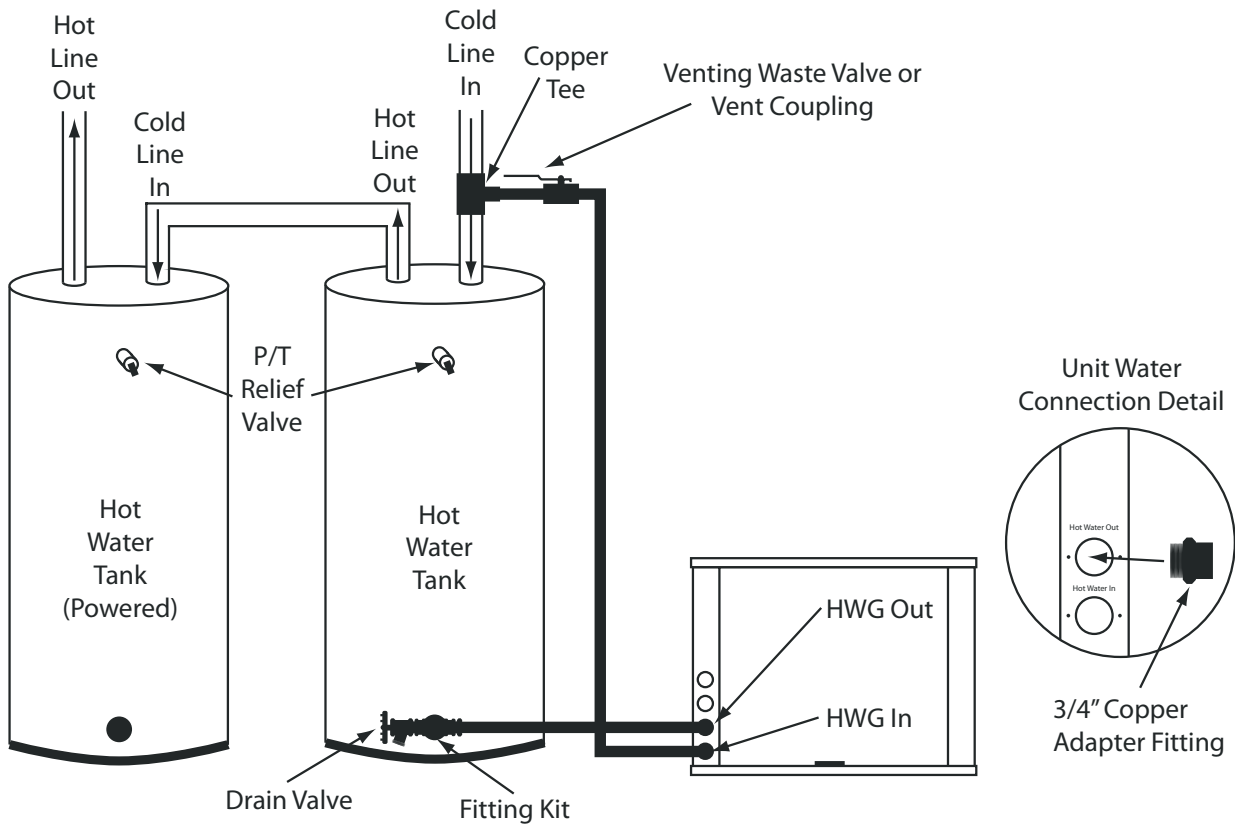

Figure 17: Desuperheater Installation in Preheat Tank



Section 10: Desuperheater Installation

Figure 18: Typical Desuperheater Installation using Marathon Hot Water Tanks

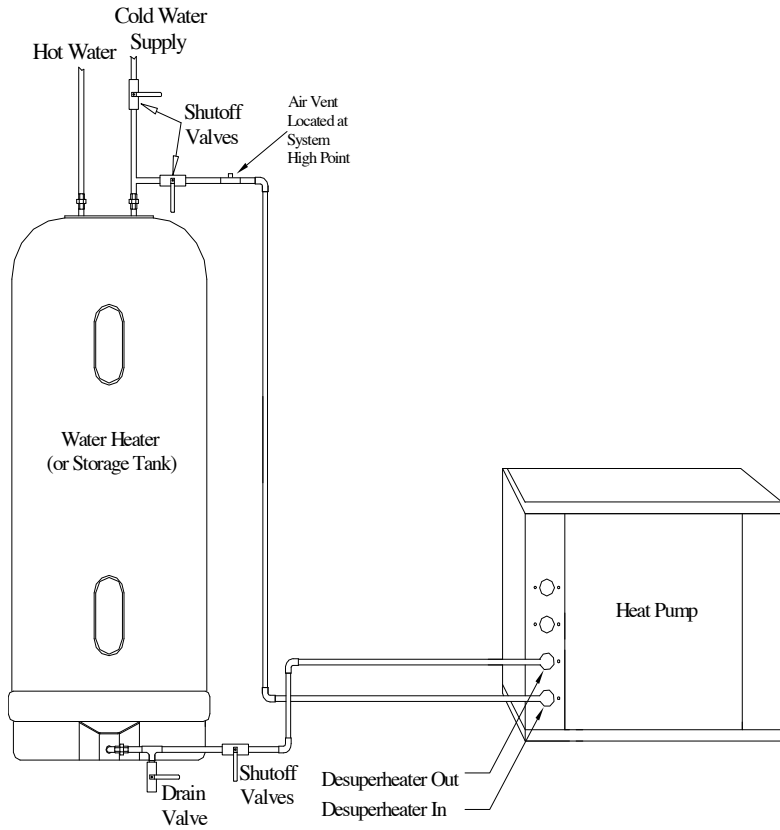
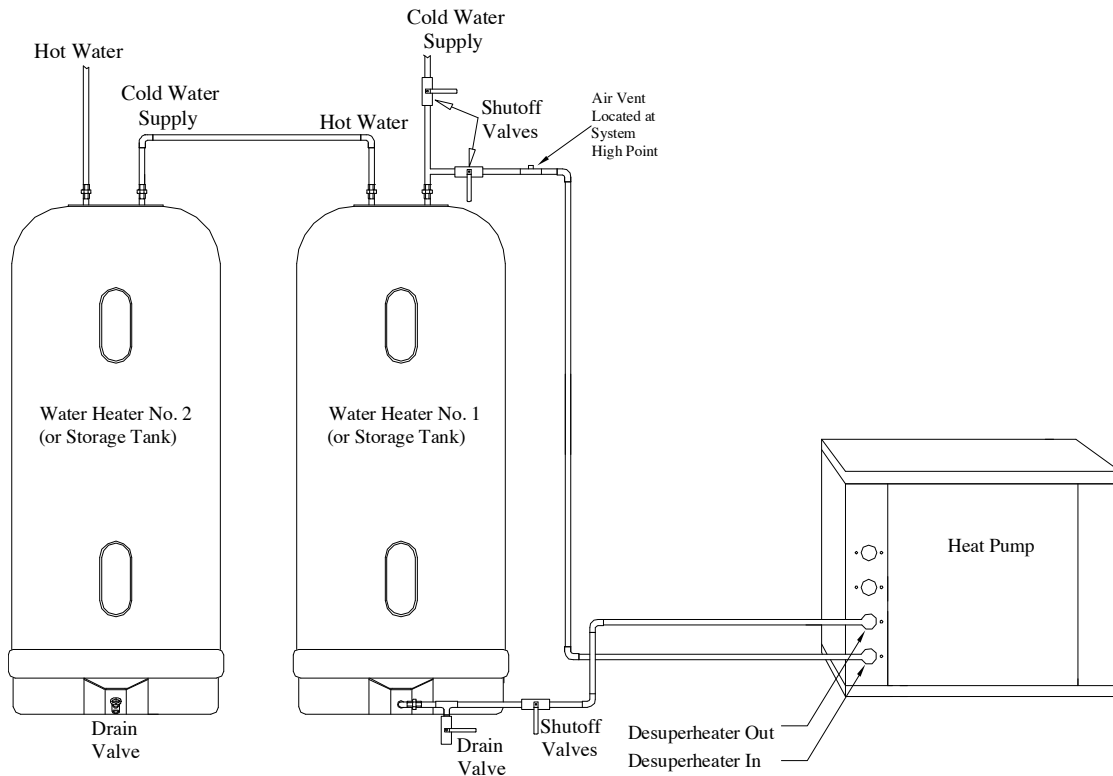

Figure 19: Desuperheater Installation in Preheat Tank using Marathon Hot Water Tanks



Section 11a: Controls

MICROPROCESSOR FEATURES AND OPERATION

Enertech Manufacturing geothermal heat pump controls provide a unique modular approach for controlling heat pump operation. The control system uses one, two, or three printed circuit boards, depending upon the features of a particular unit. This approach simplifies installation and troubleshooting, and also eliminates features that are not applicable for some units. Split units include only the lockout board in the compressor section.

A microprocessor-based printed circuit board controls the inputs to the unit as well as outputs for status mode, faults, and diagnostics. A status LED and an LED for each fault is provided for diagnostics. Removable low voltage terminal strips provide all necessary terminals for field connections.

Startup/Random Start

The unit will not operate until all the inputs and safety controls are checked for normal conditions. At first power-up, the compressor is energized after a five minute delay. In addition, a zero to sixty second random start delay is added at first power-up to avoid multiple units from being energized at the same time.

Short Cycle Protection

A built-in five minute anti-short cycle timer provides short cycle protection of the compressor.

Component Sequencing Delays

Components are sequenced and delayed for optimum space conditioning performance and to make any startup noise less noticeable.

Test Mode

The microprocessor control allows the technician to shorten most timing delays for faster diagnostics by changing the position of a jumper located on the lockout board.

Water Solenoid Valve Connections

Two accessory relay outputs at the terminal strip provide a field connection for two types of water solenoid valves, a standard 24VAC solenoid valve, or a 24VAC solenoid valve with an end switch. Additional field wiring is no longer required for operation of the end switch.

Loop Pump Circuit Breakers (Single Compressor Units)

The loop pump(s) and desuperheater pump are protected by control box mounted circuit breakers for easy wiring of pumps during installation. Circuit breakers eliminate the need to replace fuses.

Safety Controls

The control receives separate signals for high pressure, low pressure, low water flow, and condensate overflow faults. Upon a continuous 30-second measurement of the fault (immediate for high pressure), compressor operation is suspended (see Fault Retry below), and the appropriate LED flashes. Once the unit is locked out (see Fault Retry below), an output (terminal "L") is made available to a fault LED at the thermostat (water-to-water unit has fault LED on the corner post).

Low Pressure: If the low pressure switch is open for 30 continuous seconds, the compressor operation will be interrupted, and the control will go into fault retry mode. At startup, the low pressure switch is not monitored for 90 seconds to avoid nuisance faults.

High Pressure: If the high pressure switch opens, the compressor operation will be interrupted, and the control will go into fault retry mode. There is no delay from the time the switch opens and the board goes into fault retry mode. There is also no delay of switch monitoring at startup.

Flow Switch: If the flow switch is open for 30 continuous seconds, the compressor operation will be interrupted, and the control will go into fault retry mode. At startup, the flow switch is not monitored for 30 seconds to avoid nuisance faults.

FAULT RETRY

All faults are retried twice before finally locking the unit out. The fault retry feature is designed to prevent nuisance service calls. There is an anti-short cycle period between fault retries. On the third fault, the board will go into lockout mode.

Section 11a: Controls

Over/Under Voltage Shutdown

The lockout board protects the compressor from operating when an over/under voltage condition exists. The control monitors secondary voltage (24VAC) to determine if an over/under voltage condition is occurring on the primary side of the transformer. For example, if the secondary voltage is 19 VAC, the primary voltage for a 240V unit would be approximately 190V, which is below the minimum voltage (197V) recommended by the compressor manufacturer. This feature is self-resetting. If the voltage comes back within range, normal operation is restored. Therefore, over/under voltage is not a lockout.

Under voltage (18 VAC) causes the compressor to disengage and restart when the voltage returns to 20 VAC. Over voltage (31 VAC) causes the compressor to disengage and restart when the voltage returns to 29 VAC. During an over or under voltage condition, all five fault LEDs will blink (HP + LP + FS + CO + Status). When voltage returns to normal operation, the four fault LED's will stop blinking, but the status LED will continue to flash. While the board LEDs are flashing, the thermostat fault light will be illuminated.

Intelligent Reset

If the thermostat is powered off and back on (soft reset), the board will reset, but the last fault will be stored in memory for ease of troubleshooting. If power is interrupted to the board, the fault memory will be cleared.

Diagnostics

The lockout board includes five LEDs (status, high pressure, low pressure, low water flow, condensate overflow) for fast and simple control board diagnosis. On the following page is a table showing LED function.

NOTE: Condensate overflow is not used for split systems. Any condensate overflow protection must be added to the air handler.

Hot Water Pump Control

Controls for high water temperature and low compressor discharge line temperature prevent the hot water (desuperheater) pump from operating when the leaving water temperature is above 130°F, or when the compressor discharge line is too cool to provide adequate water heating.

Lockout Board Jumper Selection

The lockout board includes three jumpers for field selection of various board features.

Water Solenoid Valve Delay (WSD): When the WSD jumper is installed, the "A" terminal is energized when the compressor is energized. When the jumper is removed, the "A" terminal is energized 10 seconds after the compressor. If using the Taco water solenoid valve (or a valve with an end switch), the unit terminal strip includes a means for connecting a valve of this type. The WSD jumper should be installed. If using a fast opening valve that does not have an end switch, the jumper should be removed.

Test Mode (TEST): When the TEST jumper is installed, the board operates in the normal mode. When the jumper is removed, the board operates in test mode, which speeds up all delays for easier troubleshooting. When service is complete, the jumper must be re-installed in order to make sure that the unit operates with normal sequencing delays.

Over/Under Voltage Disable (O/V): When the O/V jumper is installed, the over/under voltage feature is active. When the jumper is removed, the over/under voltage feature is disabled. On rare occasions, variations in voltage will be outside the range of the over/under voltage feature, which may require removal of the jumper. However, removal of the jumper could cause the unit to run under adverse conditions, and therefore should not be removed without contacting technical services. An over/under voltage condition could cause premature component failure or damage to the unit controls. Any condition that would cause this fault must be thoroughly investigated before taking any action regarding the jumper removal. Likely causes of an over/under voltage condition include power company transformer selection,

Section 11a: Controls

Table 9a: LED Identification

LED Color	Location ¹	Function	Normal Operation	Fault Retry ²	Lockout ²
Green	Top	High Pressure	OFF	Flashing ³	ON ³
Orange	2nd	Low Pressure	OFF	Flashing ³	ON ³
Red	3rd	Water Flow	OFF	Flashing ³	ON ³
Yellow	4th	Condensate* Overflow	OFF	Flashing ³	ON ³
Green	Bottom	Status	Flashing ⁴	Flashing ⁵	Flashing ⁴

Notes:

1. Looking at the board when the LEDs are on the right hand side
 2. If all five lights are flashing, the fault is over/under voltage
 3. Only the light associated with the particular fault/lockout will be on or flashing.
For example, if a high pressure lockout has occurred, the top green light will be on.
The orange, red, and yellow lights will be off
 4. Status lights will be off when tin test mode
 5. Flashes alternately with the fault LED
- * Not applicable in split units

insufficient entrance wire sizing, defective breaker panel, incorrect transformer tap (unit control box), or other power-related issues.

SEQUENCE OF OPERATION

Water-to-Air Units, Single Compressor, ECM Fan

Heating, 1st Stage (Y1,G)

The ECM fan is started immediately at 75% (of 1st stage operation) CFM level, first stage compressor and the loop/desuperheater pump(s) are energized 10 seconds after the "Y1" input is received, and the ECM fan adjusts to 100% (of 1st stage operation) CFM level 30 seconds after the "Y1" input.

Heating, 2nd Stage (Y1,Y2,G)

The ECM fan adjusts to 2nd stage CFM level, and the compressor full load solenoid valve is energized.

Heat, 3rd Stage (Y1,Y2,W,G)

The ECM fan remains at 100% of 2nd stage CFM level, and the electric backup heat is energized.

Emergency Heat (W,G)

The fan is started immediately at 100% of 2nd stage CFM level, and the electric backup heat is energized.

Cooling Operation

The reversing valve is energized for cooling operation. Terminal "O" from the thermostat is connected to the reversing valve solenoid.

Cooling, 1st stage (Y1,0,G) Two-Stage Units

The ECM fan is started immediately at 75% (of 1st stage operation) CFM level, first stage compressor and the loop/desuperheater pump(s) are energized 10 seconds after the "Y1" input is received, and the ECM fan adjusts to 100% (of 1st stage operation) CFM level 30 seconds after the "Y1" input.

Cooling, 2nd Stage (Y1,Y2,O,G)

The ECM fan adjusts to 2nd stage CFM level, and the compressor full load solenoid valve is energized.

Fan Only

When the ECM control module receives a "G" call without a call for heating or cooling, the fan operates at 50% of the full load CFM level.

Thermostat Wiring / Fan Speed Notes

For two-stage compressor section units, wire as shown in the wiring diagram on the following page. For single stage units, jumper Y1 and Y2, and use the "CFM Y2" column in table 9b for determining jumper location. The ECM control board in the air handler is the thermostat connection point. Wire nut the thermostat wiring to the "pigtails" connected to the 1/4" spades on the ECM board.

Section 11a: Controls

For dehumidification in cooling, cut the resistor at the “DEHUMIDIFY” LED. Use either the HUM terminal (reverse logic -- designed to be used with a humidistat) to lower the fan speed when dehumidification is needed, or if the HUM terminal is not connected (and the resistor is cut), the air handler will operate at a lower fan speed in cooling and normal fan speed in heating.

Figure 20: Lockout Board (Compr Section)

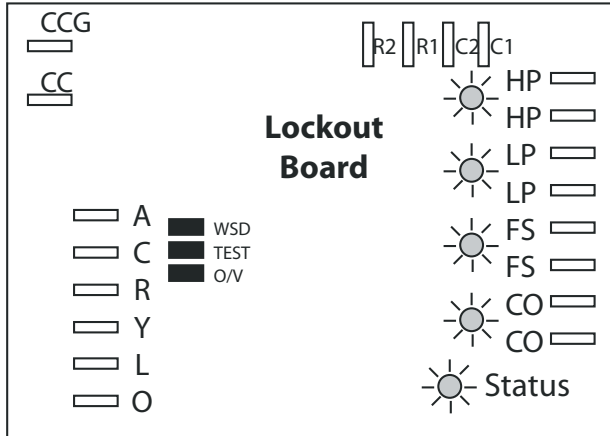
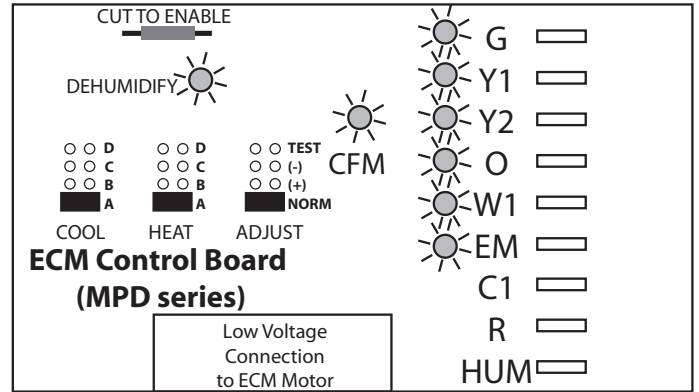

Figure 21: ECM Board (Air Handler Section)



Section 11a: Controls

Table 9b: MPD Air Handler Fan Speeds

Model	Jumpers - Notes 1,2			Full Load CFM (Y2)	Part Load CFM (Y1)	Fan Only (G)	Setting allowed with Dehumid jumper cut?
	HEAT	COOL	ADJUST	Note 3	Note 3	Note 3	
MPD024	A	A	+	1011	666	616	Yes
	B	B	+	997	614	431	Yes
	A	A	NORM	925	584	491	Yes
	C	C	+	893	569	381	Yes
	B	B	NORM	830	510	349	Yes
	D	D	+	809	492	345	Yes
	C	C	NORM	773	465	305	Yes
	D	D	NORM	699	391	259	No
MPD036	A	A	+	1545	983	776	Yes
	B	B	+	1526	975	719	Yes
	A	A	NORM	1425	901	674	Yes
	B	B	NORM	1325	832	623	Yes
	C	C	+	1177	726	540	Yes
	D	D	+	1082	655	470	Yes
	C	C	NORM	1037	624	442	No
	D	D	NORM	927	564	390	No
MPD048	A	A	+	1997	1366	1165	Yes
	B	B	+	1923	1283	1086	Yes
	C	C	+	1840	1240	1041	Yes
	A	A	NORM	1815	1232	994	Yes
	D	D	+	1732	1164	1000	Yes
	B	B	NORM	1684	1132	923	Yes
	C	C	NORM	1612	1091	891	Yes
	D	D	NORM	1506	1030	871	Yes
MPD060	B	B	+	2047	1437	1214	Yes
	C	C	+	2022	1354	1210	Yes
	A	A	+	2012	1437	1285	Yes
	A	A	NORM	2008	1388	1103	Yes
	D	D	+	1936	1312	1208	Yes
	B	B	NORM	1935	1308	1051	Yes
	C	C	NORM	1739	1193	1021	No
	D	D	NORM	1687	1138	955	No

NOTES:

1. Gray shaded areas are recommended settings. Other settings may be used, depending upon application. DO NOT cut dehumidification jumper as CFM setting will cause airflow to be too low (see last column, above).
2. The COOL and HEAT jumpers should both be set at the same position. COOL controls heating and cooling airflow; HEAT controls electric heat airflow.
3. Above CFM will be maintained up to 0.50" ESP for models MPD024 and 036, and up to 0.75" ESP for models MPD048 and 60.

Section 11a: Controls

WATER-TO-AIR SPLIT SYSTEM, TWO-STAGE OR SINGLE SPEED COMPRESSOR, SINGLE PHASE, 60 HZ

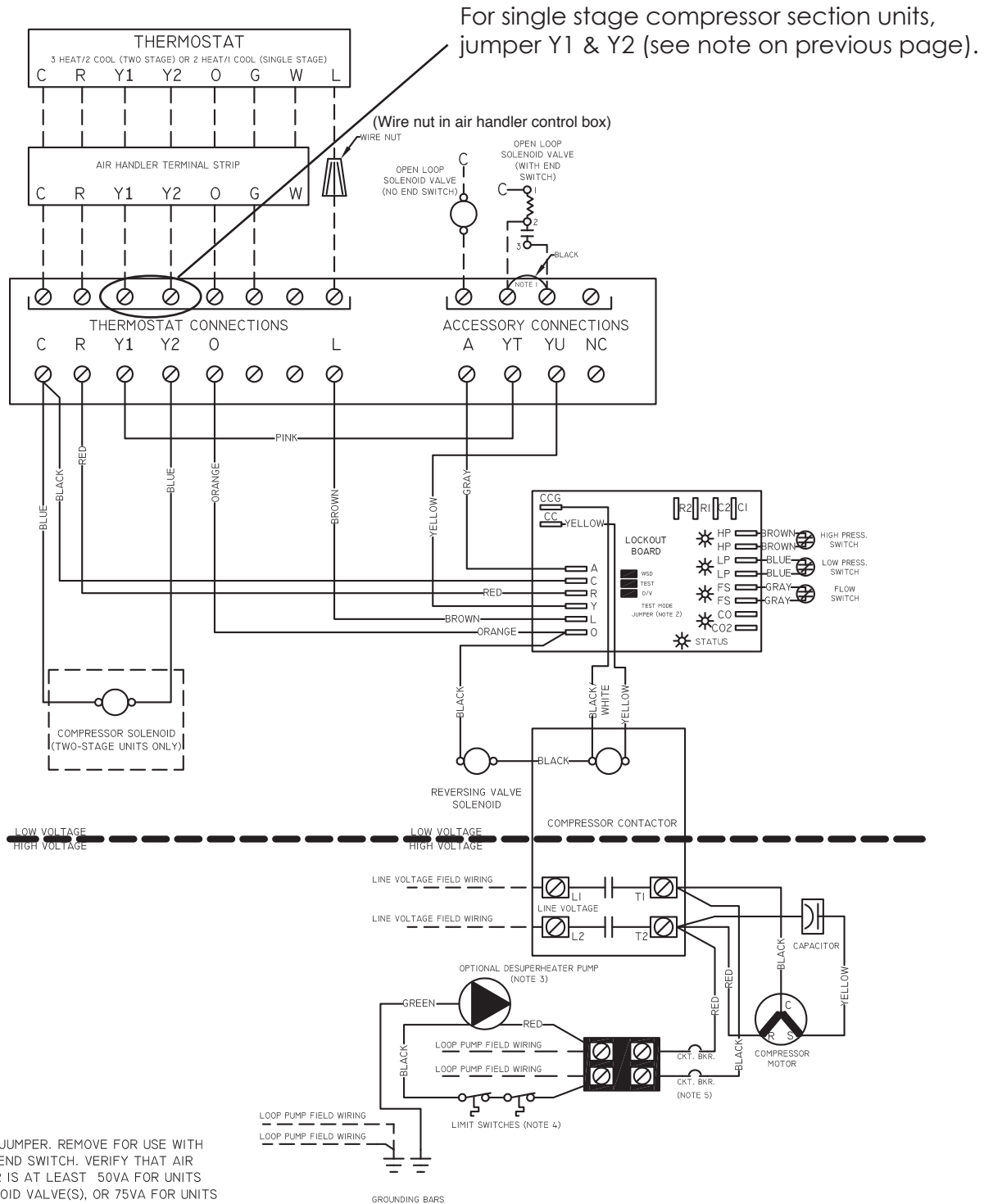

NOTES:

1. FACTORY INSTALLED JUMPER. REMOVE FOR USE WITH SOLENOID VALVE WITH END SWITCH. VERIFY THAT AIR HANDLER TRANSFORMER IS AT LEAST 50VA FOR UNITS WITHOUT WATER SOLENOID VALVE(S), OR 75VA FOR UNITS WITH WATER SOLENOID VALVE(S).
2. JUMPER INSTALLED-NORMAL; JUMPER REMOVED-TEST.
3. DESUPERHEAT PUMP POWER WIRES ARE NOT CONNECTED AT THE FACTORY. DO NOT CONNECT WIRES UNTIL THE PIPING IS COMPLETED AND PURGED OF AIR. RUNNING THE PUMP WITHOUT WATER WILL DAMAGE THE PUMP.
4. DESUPERHEATER LEAVING WATER TEMPERATURE SWITCH OR HOT GAS LINE TEMPERATURE SWITCH WILL DISENGAGE THE PUMP WHEN CONDITIONS ARE INAPPROPRIATE FOR WATER HEATING.
5. CIRCUIT BREAKERS ARE INSTALLED ON RESIDENTIAL MODELS ONLY.

Section 12: Accessories

AP SMA PUMP SHARING MODULE

The pump sharing module, part number APS-MA, is designed to allow two units to share one flow center. With the APSMA module, either unit can energize the pump(s). Connect the units and flow center as shown in Figure 23, below. Figure 24 includes a schematic of the board. The module must be mounted in a NEMA enclosure or inside the unit control box. Local code supersedes any recommendations in this document.

Figure 23: APSMA Module Layout

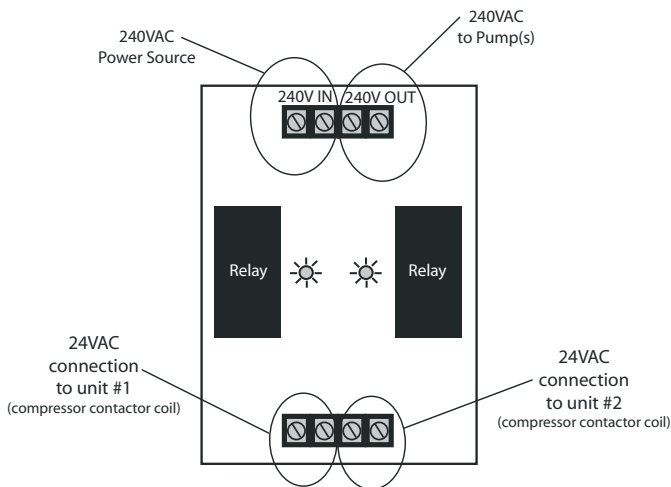
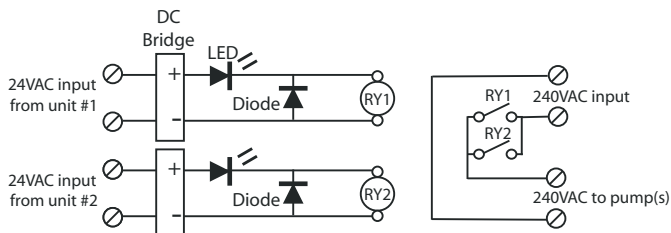

Figure 24: APSMA Module Wiring Schematic



Section 13: Troubleshooting

Table 10: R-410a Two-Stage Unit Heat of Extraction/Rejection Data (Full Load)

Two-Stage Water-to-Air Split Units (70°F EAT Heating; 75/63°F EAT Cooling)									
Heat of Extraction/Rejection-Full Load Operation (Mbtuh) -- DSP Disconnected									
EWT	Flow Rate	024 - 028		036 - 040		048 - 054		060 - 066	
°F	GPM/Ton	HE	HR	HE	HR	HE	HR	HE	HR
30	1.5	14.6		20.3		29.5		33.7	
	2.25	15.2		21.1		30.7		35.1	
	3	15.6		21.6		31.4		36.0	
50	1.5	20.4	33.0	28.4	45.8	41.2	66.5	47.1	76.1
	2.25	21.5	33.1	29.8	45.9	43.3	66.7	49.5	76.3
	3	22.0	33.3	30.5	46.2	44.4	67.1	50.8	76.7
70	1.5	25.8	32.1	35.8	44.6	52.0	64.7	59.5	74.1
	2.25	27.2	32.2	37.8	44.7	54.8	65.0	62.8	74.3
	3	28.1	32.4	38.9	45.0	56.5	65.3	64.7	74.7
90	1.5	30.4	30.9	42.2	42.9	61.3	62.3	70.1	71.3
	2.25	32.3	31.1	44.8	43.1	65.1	62.6	74.5	71.7
	3	33.4	31.1	46.4	43.2	67.4	62.7	77.1	71.8
110	1.5		29.4		40.8		59.3		67.8
	2.25		29.5		41.0		59.5		68.1
	3		29.5		41.0		59.5		68.1

Table 11: R-410a Two-Stage Unit Heat of Extraction/Rejection Data (Part Load)

Two-Stage Water-to-Air Split Units (70°F EAT Heating; 75/63°F EAT Cooling)									
Heat of Extraction/Rejection-Part Load Operation (Mbtuh) -- DSP Disconnected									
EWT	Flow Rate	024 - 028		036 - 040		048 - 054		060 - 066	
°F	GPM/Ton	HE	HR	HE	HR	HE	HR	HE	HR
30	1.5	10.1		13.6		19.6		23.6	
	2.25	10.5		14.1		20.4		24.6	
	3	10.8		14.5		20.9		25.2	
50	1.5	14.1	22.8	18.9	30.6	27.3	44.1	33.0	53.2
	2.25	14.8	22.8	19.9	30.7	28.7	44.3	34.6	53.4
	3	15.2	23.0	20.4	30.8	29.4	44.5	35.5	53.6
70	1.5	17.8	22.2	23.9	29.7	34.5	42.9	41.6	51.8
	2.25	18.8	22.2	25.2	29.9	36.4	43.1	43.9	52.0
	3	19.4	22.4	26.0	30.0	37.5	43.3	45.2	52.2
90	1.5	21.0	21.3	28.2	28.6	40.7	41.3	49.0	49.8
	2.25	22.3	21.4	29.9	28.8	43.2	41.6	52.1	50.1
	3	23.1	21.5	31.0	28.8	44.7	41.6	53.9	50.2
110	1.5		20.3		27.2		39.3		47.4
	2.25		20.4		27.3		39.5		47.6
	3		20.4		27.3		39.5		47.6

Section 13: Troubleshooting

Table 12: R-410a Two-Stage Unit Heat Exchanger Pressure Drop (Full Load)

Two-Stage Water-to-Air Split Units						
Heat Exchanger Pressure Drop						
Full Load Operation		Pressure Drop at Entering Water Temp. Listed Below				
Model	Flow Rate GPM	30°F PSI	50°F PSI	70°F PSI	90°F PSI	110°F PSI
024 - 028	3.9	1.4	1.3	1.3	1.2	1.2
	5.4	2.6	2.4	2.3	2.1	2.1
	7.0	4.1	3.9	3.7	3.4	3.4
030 - 040	5.0	1.8	1.7	1.7	1.6	1.5
	7.0	3.4	3.1	3.0	2.8	2.8
	9.0	5.4	5.0	4.8	4.4	4.4
048 - 054	6.7	2.2	2.0	2.0	1.9	1.9
	9.3	4.0	3.7	3.6	3.3	3.3
	12.0	6.5	6.0	5.8	5.3	5.3
060 - 066	8.3	2.2	2.1	2.1	1.9	1.9
	11.7	4.1	3.8	3.7	3.4	3.4
	15.0	6.7	6.2	5.9	5.5	5.4

Table 13: R-410a Two-Stage Unit Heat Exchanger Pressure Drop (Part Load)

Two-Stage Water-to-Air Split Units						
Heat Exchanger Pressure Drop						
Part Load Operation		Pressure Drop at Entering Water Temp. Listed Below				
Model	Flow Rate GPM	30°F PSI	50°F PSI	70°F PSI	90°F PSI	110°F PSI
024 - 028	2.2	0.9	0.8	0.8	0.8	0.8
	3.1	1.7	1.6	1.5	1.4	1.4
	4.0	2.7	2.5	2.4	2.2	2.2
030 - 040	2.8	1.2	1.1	1.1	1.0	1.0
	3.9	2.2	2.0	2.0	1.8	1.8
	5.0	3.5	3.3	3.1	2.9	2.8
048 - 054	3.9	1.4	1.3	1.3	1.2	1.2
	5.4	2.6	2.4	2.3	2.1	2.1
	7.0	4.1	3.9	3.7	3.4	3.4
060 - 066	5.6	1.4	1.3	1.3	1.2	1.2
	7.8	2.7	2.5	2.4	2.2	2.2
	10.0	4.3	4.0	3.8	3.6	3.5

Section 13: Troubleshooting

Table 14: R-410a Single Stage Unit Heat of Extraction/Rejection Data

Single-Stage Water-to-Air Split Units (70°F EAT Heating; 75/63°F EAT Cooling)																	
Heat of Extraction/Rejection-Full Load Operation (Mbtuh) -- DSP Disconnected																	
EWT	Flow Rate GPM/ Ton	018		024		030		036		042		048		060		072	
°F		HE	HR	HE	HR	HE	HR	HE	HR	HE	HR	HE	HR	HE	HR	HE	HR
30	1.5	9.1		13.6		17.6		20.4		23.8		28.9		32.3		39.7	
	2.25	9.4		14.2		18.3		21.3		24.8		30.1		33.7		41.3	
	3	9.7		14.5		18.7		21.8		25.4		30.8		34.5		42.3	
50	1.5	12.7	20.5	19.0	30.7	24.6	39.6	28.5	46.0	33.3	53.7	40.4	65.2	45.2	72.9	55.4	89.5
	2.25	13.3	20.5	20.0	30.6	25.8	39.8	30.0	46.2	34.9	53.9	42.4	65.4	47.4	73.1	58.2	89.8
	3	13.6	20.6	20.5	30.9	26.4	40.0	30.7	46.4	35.8	54.2	43.5	65.8	48.6	73.5	59.7	90.3
70	1.5	16.0	19.9	24.0	29.9	31.0	38.6	36.0	44.8	42.0	52.3	51.0	63.5	57.0	70.9	70.1	87.1
	2.25	16.9	20.0	25.3	30.0	32.7	38.7	38.0	45.0	44.3	52.5	53.8	63.7	60.1	71.2	73.4	87.4
	3	17.4	20.1	26.1	30.1	33.7	38.9	39.1	45.2	45.7	52.7	55.5	64.1	62.0	71.6	76.1	87.9
90	1.5	18.9	19.2	28.3	28.7	36.5	37.1	42.4	43.1	49.5	50.3	60.1	31.1	67.2	68.3	82.5	83.8
	2.25	20.0	19.3	30.0	28.9	38.8	37.3	45.1	43.4	52.6	50.6	63.8	61.4	71.3	68.7	87.6	84.3
	3	20.7	19.3	31.1	29.0	40.2	37.4	46.7	43.4	54.4	50.7	66.1	61.5	73.9	68.8	90.7	84.5
110	1.5		18.2		27.3		35.3		41.0		47.9		58.1		65.0		79.8
	2.25		18.3		27.5		35.5		41.2		48.0		58.3		65.2		80.1
	3		18.3		27.5		35.5		41.2		48.0		58.3		65.2		80.1

Section 13: Troubleshooting

Table 15: R-410a Single Stage Unit Heat Exchanger Pressure Drop

Single-Stage Water-to-Air Split Units						
Heat Exchanger Pressure Drop						
Model	Flow Rate GPM	Pressure Drop at Entering Water Temp Listed Below				
		30°F PSI	50°F PSI	70°F PSI	90°F PSI	110°F PSI
018	2.8	1.2	1.1	1.1	1.0	1.0
	3.9	2.2	2.1	2.0	1.8	1.8
	5.0	3.6	3.4	3.2	3.0	3.0
024	3.3	1.4	1.3	1.3	1.2	1.2
	4.7	2.5	2.3	2.3	2.1	2.1
	6.0	4.1	3.8	3.6	3.3	3.3
030	3.9	1.4	1.3	1.3	1.2	1.2
	5.4	2.5	2.3	2.3	2.1	2.1
	7.0	4.1	3.8	3.6	3.3	3.3
036	5.0	1.8	1.7	1.7	1.6	1.6
	7.0	3.4	3.1	3.0	2.8	2.8
	9.0	5.4	5.0	4.8	4.4	4.4
042	6.1	1.5	1.4	1.4	1.3	1.3
	8.5	2.8	2.6	2.5	2.3	2.3
	11.0	4.5	4.2	4.0	3.7	3.7
048	7.2	2.2	2.0	2.0	1.9	1.9
	10.1	4.0	3.7	3.6	3.3	3.3
	13.0	6.5	6.0	5.8	5.3	5.3
060	8.3	2.2	2.1	2.1	1.9	1.9
	11.7	4.1	3.8	3.7	3.4	3.4
	15.0	6.7	6.2	5.9	5.5	5.5
072	10.0	2.3	2.2	2.2	2.0	2.0
	14.0	4.4	4.1	3.9	3.6	3.6
	18.0	7.0	6.6	6.2	5.8	5.8

Section 13: Troubleshooting

Table 16: Unit Operating Pressures (R-410a)

Heating - Without Desuperheater							
EWT (°F)	GPM Per Ton	Discharge Pressure (PSIG)	Suction Pressure (PSIG)	Sub Cooling (°F)	Super Heat (°F)	Air Temperature Rise (°F-DB)	Water Temperature Drop (°F)
30	1.5	285-310	68-76	4-10	8-12	14-20	5-8
	3	290-315	70-80	4-10	8-12	16-22	3-6
50	1.5	315-345	100-110	6-12	9-14	22-28	7-10
	3	320-350	105-115	6-12	9-14	24-30	5-8
70	1.5	355-395	135-145	7-12	10-15	30-36	9-12
	3	360-390	140-150	7-12	10-15	32-38	7-10
Cooling - Without Desuperheater							
EWT (°F)	GPM Per Ton	Discharge Pressure (PSIG)	Suction Pressure (PSIG)	Sub Cooling (°F)	Super Heat (°F)	Air Temperature Drop (°F-DB)	Water Temperature Rise (°F)
50	1.5	220-235	120-130	10-16	12-20	20-26	19-23
	3	190-210	120-130	10-16	12-20	20-26	9-12
70	1.5	280-300	125-135	8-14	10-16	19-24	18-22
	3	250-270	125-135	8-14	10-16	19-24	9-12
90	1.5	360-380	130-145	8-14	10-14	18-22	17-21
	3	330-350	130-140	8-14	10-14	18-22	8-11

Table 17: Unit Operating Pressures (R22)

Heating - Without Desuperheater		
EWT (°F)	Discharge Pressure (PSIG)	Suction Pressure (PSIG)
32	180 - 205	36 - 46
40	200 - 220	42 - 52
50	220 - 240	50 - 63
Cooling - Without Desuperheater		
EWT (°F)	Discharge Pressure (PSIG)	Suction Pressure (PSIG)
65	140 - 170	60 - 66
85	165 - 205	65 - 70

PERFORMANCE CHECK

Heat of Extraction(HE)/Rejection(HR)
Record information on the Unit Start-up Form

Equipment should be in operation for a minimum of 10 minutes in either mode – **WITH THE HOT WATER GENERATOR TURNED OFF.**

- Determine flow rate in gallons per minute
 - Check entering water temperature
 - Check entering water pressure
 - Check leaving water pressure

Once this information is recorded, find corresponding entering water temperature column in Specification Manual for unit. Find pressure differential in PSI column in Spec Manual. Then read the GPM column in Spec Manual to determine flow in GPM.

- Check leaving water temperature of unit.
FORMULA: $[GPM \times \text{water temp diff} \times 485 (\text{antifreeze})] / 500 (\text{fresh water}) = \text{HE or HR in BTU/HR}$

A 10% variance from Spec Manual is allowed. Always use the same pressure gauge & temperature measuring device. Water flow must be in range of Specification Manual. If system has too much water flow, performance problems should be expected

Section 13: Troubleshooting

A: UNIT WILL NOT START IN EITHER CYCLE

Thermostat	Set thermostat on heating and highest temperature setting. Unit should run. Set thermostat on cooling and lowest temperature setting. Unit should run. Set fan to On position. Fan should run. If unit does not run in any position, disconnect wires at heat pump terminal block and jump R, G, Y. Unit should run in heating. If unit runs, replace thermostat with correct thermostat only.
Loose or broken wires	Tighten or replace wires.
Blown Fuse/ Tripped Circuit Breakers	Check fuse size, replace fuse or reset circuit breaker. Check low voltage circuit breaker.
Low Voltage Circuit	Check 24 volt transformer. If burned out or less than 24 volt, replace. Before replacing, verify tap setting and correct if necessary.
Water Flow	If water flow is low (less than 1 GPM), unit will not start. Make sure Pump Module or solenoid valve is connected (see wiring diagram). Water has to flow through the heat exchanger in the right direction (see labels at water fitting connections) before the compressor can start. If water flow is at normal flow, use an ohmmeter to check if you get continuity at the flow switch. If no switch is open and flow is a normal flow, remove switch and check for stuck particles or bad switch.

B: UNIT RUNNING NORMAL, BUT SPACE TEMPERATURE IS UNSTABLE

Thermostat	Thermostat is getting a draft of cold or warm air. Make sure that the wall or hole used to run thermostat wire from the ceiling or basement is sealed, so no draft can come to the thermostat. Faulty Thermostat (Replace).
------------	--

C: NO WATER FLOW

Pump Module	Make sure Pump Module is connected to the control box relay (check all electrical connections). For non-pressurized systems, check water level in Pump Module. If full of water, check pump. Close valve on the pump flanges and loosen pump. Take off pump and see if there is an obstruction in the pump. If pump is defective, replace. For pressurized systems, check loop pressure. Repressurize if necessary. May require re-flushing if there is air in the loop.
Solenoid valve	Make sure solenoid valve is connected. Check solenoid. If defective, replace.

D: IN HEATING OR COOLING MODE, UNIT OUTPUT IS LOW

Water	Water flow & temperature insufficient.
Airflow	Check speed setting, check nameplate or data manual for proper speed, and correct speed setting. Check for dirty air filter—Clean or replace. Restricted or leaky ductwork. Repair.
Refrigerant charge	Refrigerant charge low, causing inefficient operation. Make adjustments only after airflow and water flow are checked.
Reversing valve	Defective reversing valve can create bypass of refrigerant to suction side of compressor. Switch reversing valve to heating and cooling mode rapidly. If problem is not resolved, replace valve. Wrap the valve with a wet cloth and direct the heat away from the valve. Excessive heat can damage the valve. Always use dry nitrogen when brazing. Replace filter/drier any time the circuit is opened.

E: IN HEATING OR COOLING MODE, UNIT OUTPUT IS LOW

Heat pump will not cool but will heat. Heat pump will not heat but will cool.	Reversing valve does not shift. Check reversing valve wiring. If wired wrong, correct wiring. If reversing valve is stuck, replace valve. Wrap the valve with a wet cloth and direct the heat away from the valve. Excessive heat can damage the valve. Always use dry nitrogen when brazing. Replace filter/drier any time the circuit is opened.
Water heat exchanger	Check for high-pressure drop, or low temperature drop across the coil. It could be scaled. If scaled, clean with condenser coil cleaner.
System undersized	Recalculate conditioning load.

F: WATER HEAT EXCHANGER FREEZES IN HEATING MODE

Water flow	Low water flow. Increase flow. See F. No water flow.
Flow Switch	Check switch. If defective, replace.

G: EXCESSIVE HEAD PRESSURE IN COOLING MODE

Inadequate water flow	Low water flow, increase flow.
-----------------------	--------------------------------

Section 13: Troubleshooting

H: EXCESSIVE HEAD PRESSURE IN HEATING MODE

Low air flow	See E: Noisy blower and low air flow.
--------------	---------------------------------------

I: AIR COIL FREEZES OVER IN COOLING MODE

Air flow	See E: Noisy blower and low air flow.
Blower motor	Motor not running or running too slow. Motor tripping off on overload. Check for overheated blower motor and tripped overload. Replace motor if defective.
Panels	Panels not in place.
Low air flow	See E: Noisy blower and low air flow.

J: WATER DRIPPING FROM UNIT

Unit not level	Level unit.
Condensation drain line plugged	Unplug condensation line.
Water sucking off the air coil in cooling mode	Too much airflow. Duct work not completely installed. If duct work is not completely installed, finish duct work. Check static pressure and compare with air flow chart in spec manual under specific models section. If ductwork is completely installed it may be necessary to reduce CFM.
Water sucking out of the drain pan	Install an EZ-Trap or P-Trap on the drain outlet so blower cannot suck air back through the drain outlet.

Section 13: Troubleshooting

O: COMPRESSOR WON'T START

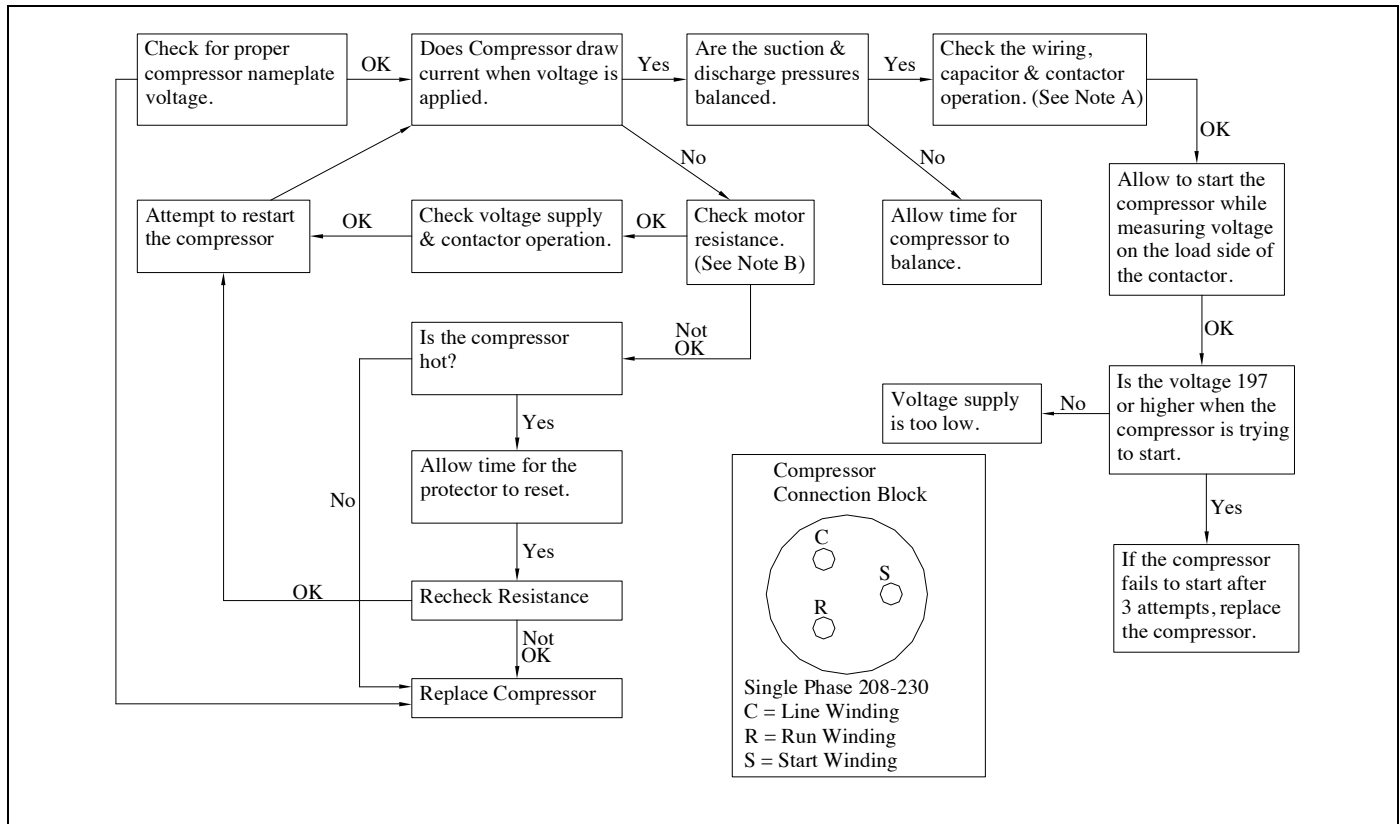

A: Check all terminals, wires & connections for loose or burned wires and connections. Check contactor and 24 Volt coil. Check capacitor connections & check capacitor with capacitor tester.

B: If ohm meter reads 0 (short) resistance from C to S, S to R, R to C or from anyone of one of these terminals to ground (shorted to ground), compressor is bad.

P: COMPRESSOR WON'T PUMP CHART

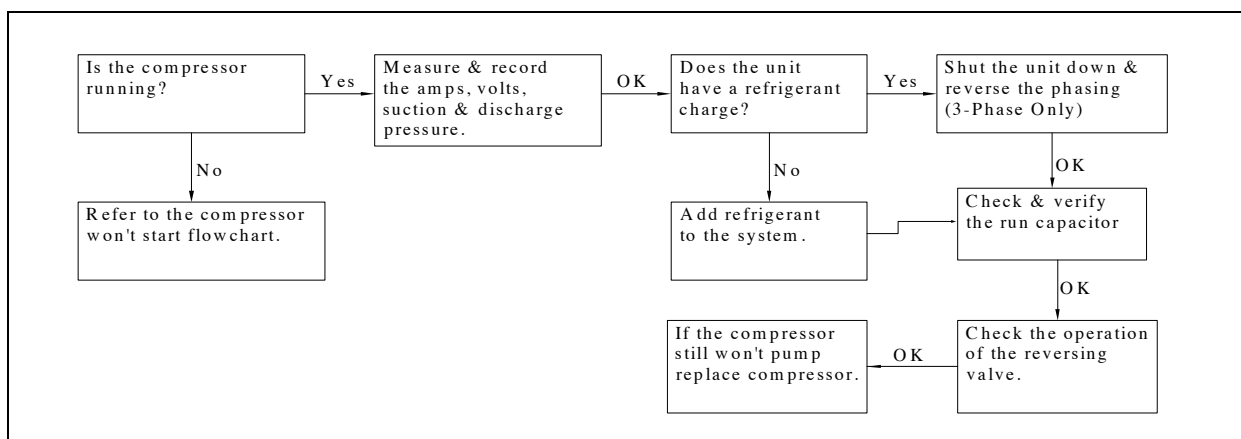

Section 13: Troubleshooting

Table 18: Refrigeration Troubleshooting

System Faults		Air Flow	Water Flow	Under Charge	Over Charge	Super Heat	Subcooling
Head Pressure Too High	Heat	P - Too Low			P		
	Cool		P - Too Low		P		
Head Pressure Too Low	Heat		P - Too Low	P		High	Low
	Cool	P - Too Low	S - Too High	P		High	Low
Suction Pressure Too High	Heat	P - Too Low					High
	Cool				P		High
Suction Pressure Too Low	Heat		P - Too Low	P		High	Low
	Cool	P - Too Low		P		High	Low
Liquid Refrigerant Flood Back	Heat				P		High
	Cool				P		High
Air Coil Frosting	Heat						
	Cool	P - Too Low		P		High	Low
Compressor Runs Inadequate. Or No Cooling/Heating	Heat	S - Too High	P - Too Low	P		High	Low
	Cool	S - Too High	P - Too Low	P		High	Low

P - Primary causes (most common problems) S - Secondary causes (problems that occur, but are not common)

Section 14: Forms - Troubleshooting

Customer/Job Name: _____ Date: _____

Model #: _____ Serial #: _____

Antifreeze Type: _____

$HE \text{ or } HR = GPM \times TD \times \text{Fluid Factor}$
 (Use 500 for water; 485 for antifreeze)

SH = Suction Temp. - Suction Sat.
 SC = Disch. Sat. - Liq. Line Temp.

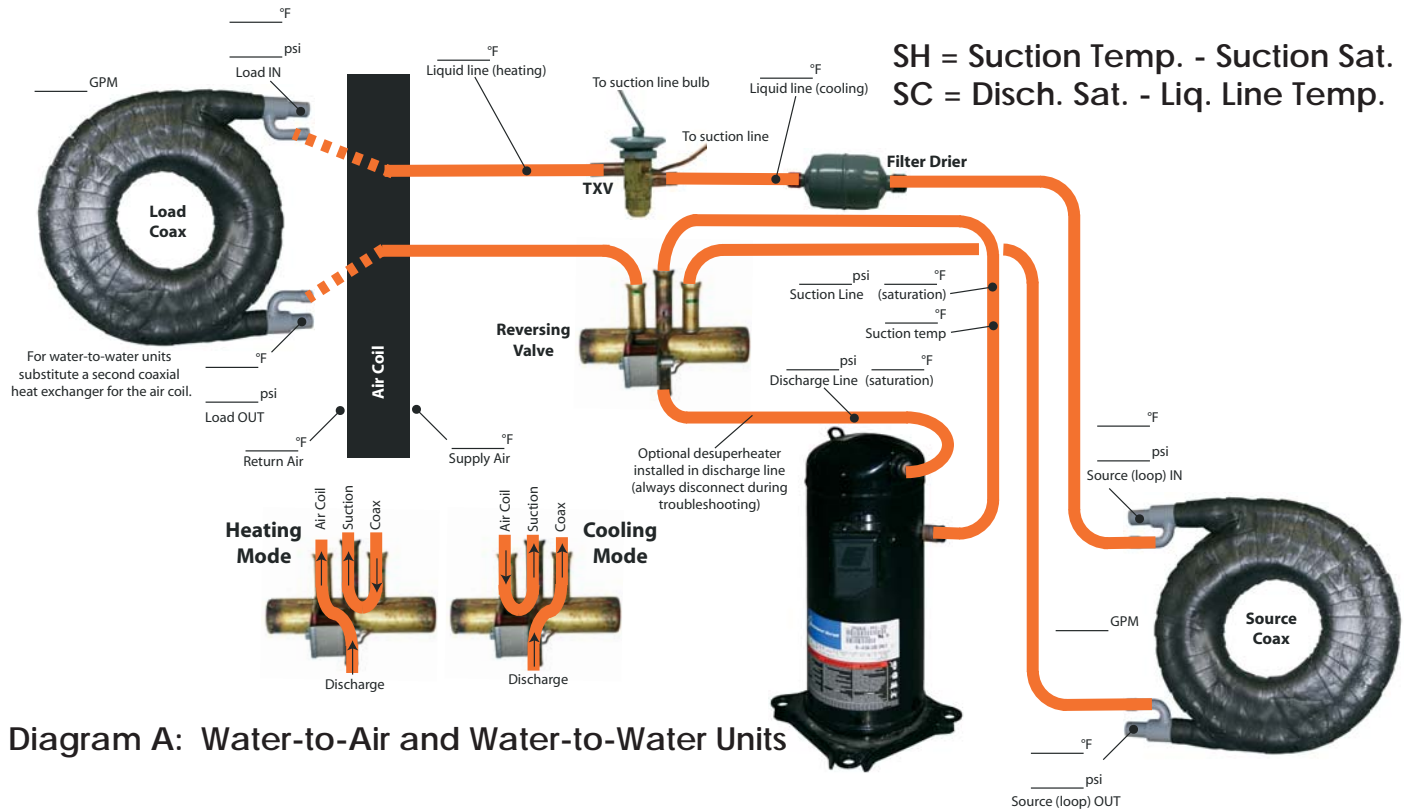

Diagram A: Water-to-Air and Water-to-Water Units

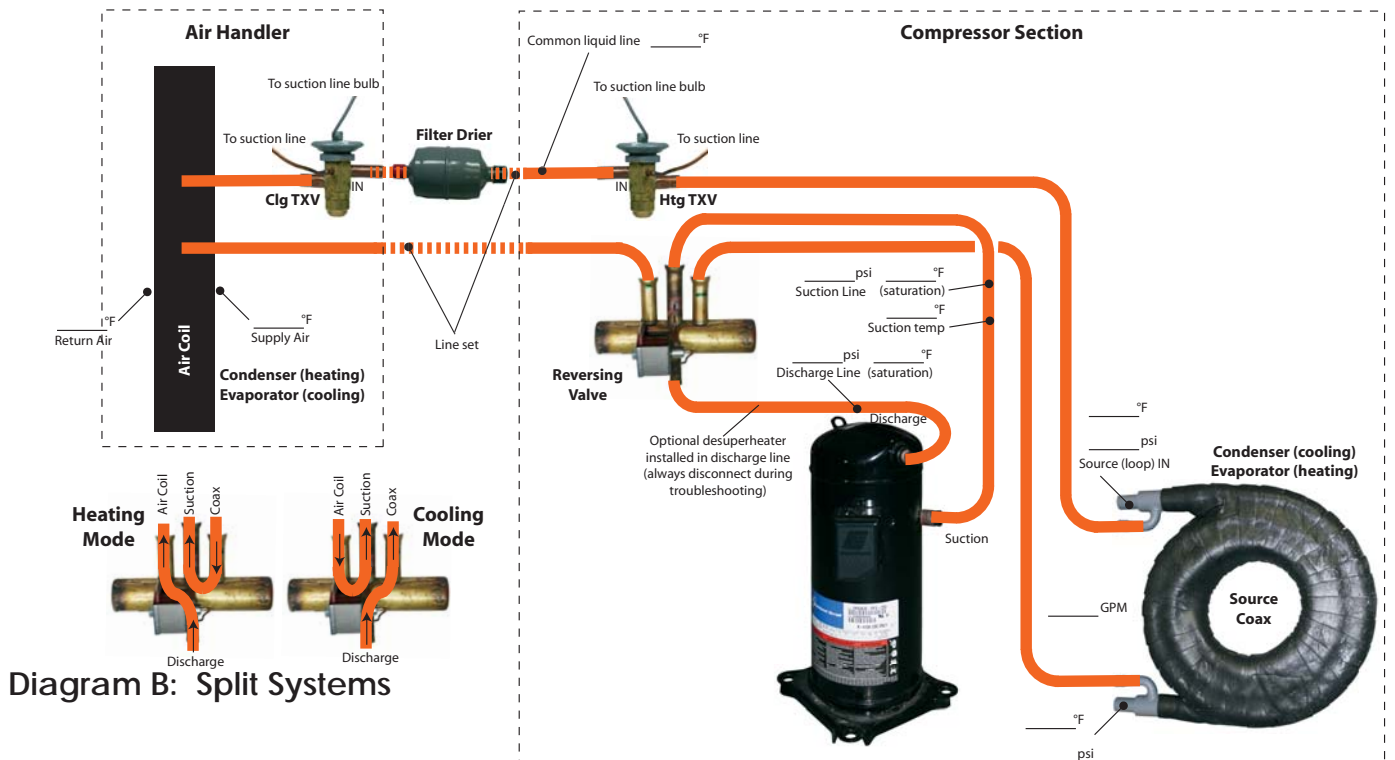

Diagram B: Split Systems

EQUIPMENT START-UP FORM

Customer/Job Name: _____ Date: _____

Model #: _____ Serial #: _____

Dealer Name: _____

Check the following before power is applied to the equipment

Note: Start-Up should not occur until the structure is ready to be occupied

ELECTRICAL:

- High voltage wiring is installed correctly
- High voltage wiring & breaker are the correct size
- Auxiliary electric heaters are wired and installed correctly
- Circulating pumps are wired and fused (if necessary) correctly
- Desuperheater pump (if applicable) is NOT wired, unless piping is complete and all air is purged
- Low voltage wiring is correct and completely installed

PLUMBING:

- Pipe and pump sizes are correct
- Air is purged from all lines
- Antifreeze is installed
- All valves are open, including those on the pump kit
- Condensate is trapped and piped to the drain

DUCTWORK:

- Filter is installed and clean
- Packaging is removed from the blower assembly
- Blower turns freely

Equipment Start-Up

Note: Steps should be followed in order

Note: Equipment operation will vary with thermostat brand and model. Refer to thermostat instructions

1. Energize equipment with high voltage.
2. Be sure all pumps and valves are open.
3. Set thermostat settings to correspond with application, and set thermostat to "Heat". Place set point above room temperature. Compressor will start after thermostat time delay expires.
4. Check water flow via one or a combination of these 3 methods:
 - A: ΔT (temp difference):
Source (5°-10° F) _____
 - B: Flowmeter:
3 gpm (gallons per minute) per nominal ton of equipment. (Open Loop 1.5 to 2 GPM).
 - C: Pressure Drop:
Refer to Table 12, 13, & 15.
5. Check ΔT of return and discharge air. (18°-30°F) _____
6. If system is two stage or dual capacity, increase set point and verify that second stage engages (increasing air flow). ΔT will remain the same.
7. If system has auxiliary heat, increase set point and verify that auxiliary heat engages ΔT will increase.
8. Switch thermostat to off, Compressor will shutoff.
9. Place thermostat in "Cooling" and decrease set point below room temperature. Compressor will start after thermostat time delay expires.
10. Check water flow via and one or combination of these 3 methods:
 - A. ΔT (temp difference).
Source (6°-12° F) _____
 - B. Flowmeter.
3 GPM (gallons per minute) per nominal ton of equipment. (Open Loop 1.5 to 2 GPM).
 - C. Pressure Drop.
Refer to Table 13.
11. Check ΔT of return and discharge air. 16°-25° F _____
12. If system is two stage or dual capacity, increase set point and verify that second stage engages (increasing air flow). ΔT will remain the same.
13. If, at anytime, there is excessive noise or vibration, the problem should be fixed and testing resumed.

Note: If a problem occurs during start-up, please do the following:

1. Refer to the troubleshooting sections contained within the unit Installation, Operation, and Maintenance Manual
2. Contact Technical Support at your distributor.

Installer/Technician: _____ Date: _____

Cut along this line



2506 South Elm Street
Greenville, IL 62246
www.enertechmfg.com
info@enertechmfg.com



Enertech Manufacturing is continually working to improve its products. As a result, the design and specifications of each product may change without notice and may not be as described herein. For the most up-to-date information, please visit our website, or contact our Customer Service department at info@enertechmfg.com. Statements and other information contained herein are not express warranties and do not form the basis of any bargain between the parties, but are merely Enertech Manufacturing's opinion or commendation of its products.